



Electrical position feedback for pneumatically operated process valves

- Fast and easy installation
- Compact design



Product variants described in the data sheet may differ from the product presentation and description.

Can be combined with



Type 0330/0331 ▶
Direct-acting
2/2 or 3/2-way pivoted
armature valve



Type 2XXX ▶
Accessories for
pneumatic stroke and
rotary actuators

Type description

The electrical position feedback Type 1060 is designed for integrated mounting on CLASSIC Series process valves. Due to its simple and a very compact design, the position feedback can easily be mounted on a valve. Depending on the switch type of the electrical position feedback, the positions of the valve are reported electrically: open, closed.

Table of contents

1. General technical data	3
2. Dimensions	4
3. Device/Process connections	5
3.1. Electrical connection.....	5
4. Product installation	6
4.1. Electrical connection instructions	6
5. Ordering information	6
5.1. Bürkert eShop	6
5.2. Bürkert product filter	6

DTS 1000282018 EN Version: C Status: RL (released | freigegeben | validé) printed: 31.10.2023

1. General technical data

Product properties	
Dimensions	Further information can be found in chapter "2. Dimensions" on page 4.
Material	
Housing	PA6 GF30
Limit switch insert	PBT (Polybutylene terephthalate)
Operation	
Micro switch	1 switch over contact
Application	Electrical feedback (alarm-, emergency-, off-, follow-circuits, etc.) for solenoid valves, diaphragm valves, piston valves, gate valves
Electrical data	
Contact rating	
Up to 250 V AC	Maximal ohmic contact load: 5 A Maximal inductive contact load: 5 A Maximal filament load: 0.5 A
Up to 250 V DC	Maximal ohmic contact load: 0.25 A Maximal inductive load: 0.02 A Maximal filament load: 0.02 A
Environment and installation	
Operating conditions	
Maximal continuous temperature	+125 °C
Degree of protection	IP65 DIN 40050 with suitable counterpart piece
Installation and mechanical data	
Cable outlet	Adjustable by turning 4 x 90°
Connection	Solder connections
Fixing	With cylindrical screw M3 x 28 resp. M3 x 30
Cable diameter	5...9 mm

2. Dimensions

Note:

Dimensions in mm

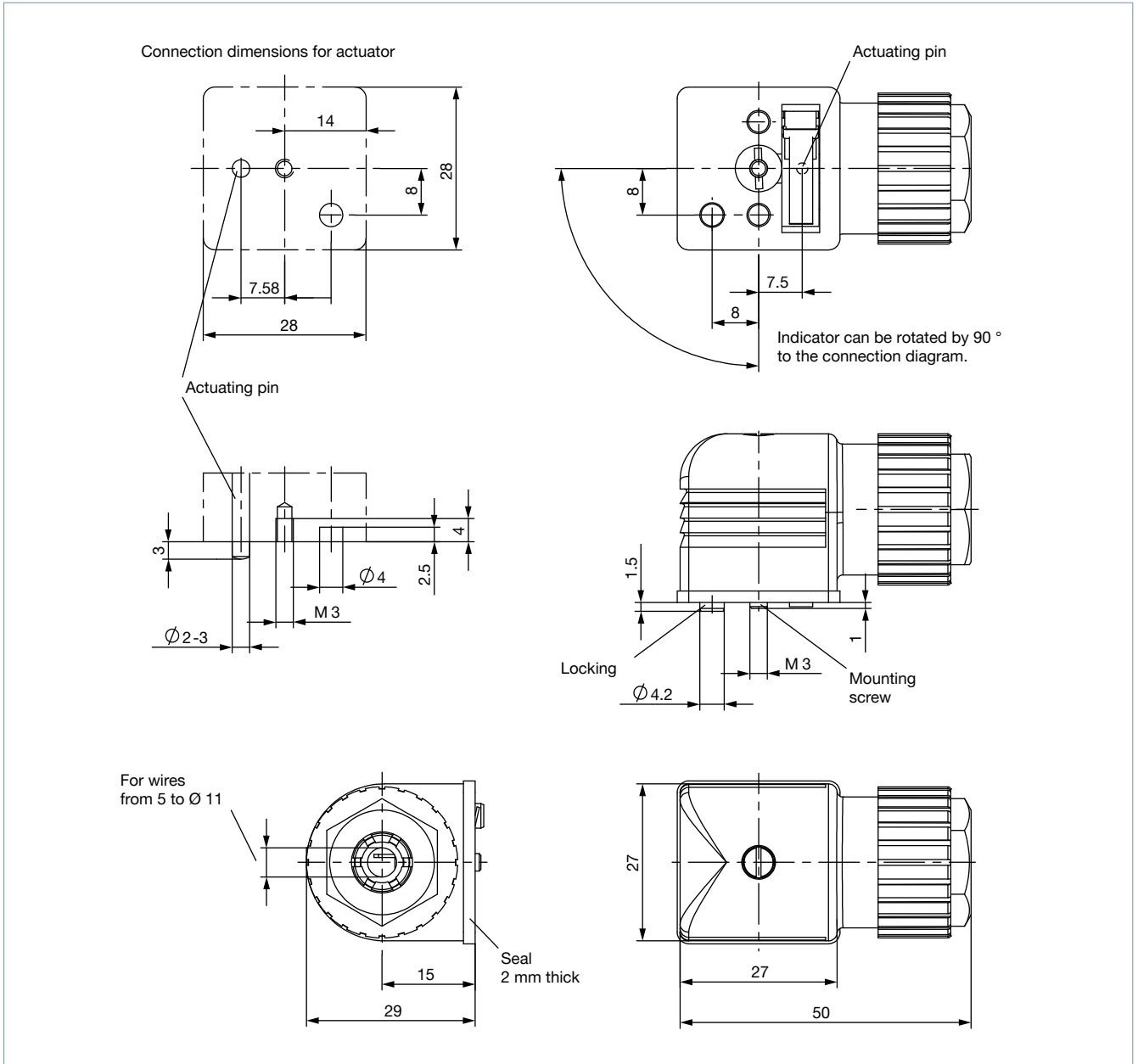

DTS 1000282018 EN Version: C Status: RL (released | freigegeben | valide) printed: 31.10.2023

3. Device/Process connections

3.1. Electrical connection

Connection	Pin	Pin assignment
	1	Input
	2	Break contact
	3	Make contact

Connection	No.	Description
	1	Solder connection

DTS 1000282018 EN Version: C Status: RL (released | freigegeben | validé) printed: 31.10.2023

4. Product installation

4.1. Electrical connection instructions

1. Loosen screws (2) in contact insert (3) and remove contact insert.
2. Feed cable through union nut (6).
3. Connect according to electrical connection scheme.
4. Insert contact insert (3) into cap (5) and fasten with screw (2).
5. Fasten the complete cap with cap screw (4), making sure that the flat gasket (1) is securely seated.
6. Check the valve for function.

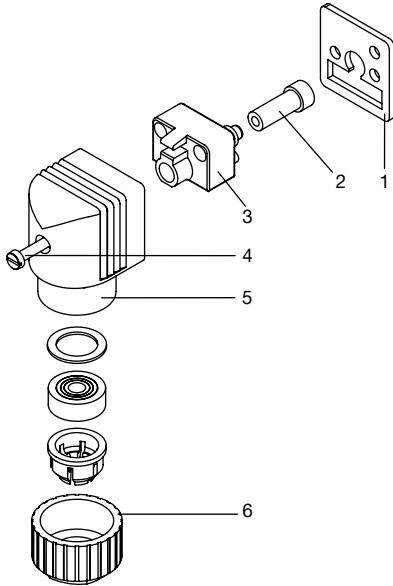

No.	Description
1	Flat seal
2	Screw
3	Contact insert
4	Cylinder screw
5	Cap
6	Union nut

5. Ordering information

5.1. Bürkert eShop



Bürkert eShop – Easy ordering and quick delivery

You want to find your desired Bürkert product or spare part quickly and order directly? Our online shop is available for you 24/7. Sign up and enjoy all the benefits.

[Order online now](#)

5.2. Bürkert product filter



Bürkert product filter – Get quickly to the right product

You want to select products comfortably based on your technical requirements? Use the Bürkert product filter and find suitable articles for your application quickly and easily.

[Try out our product filter](#)