



## Direct-acting 2/2 or 3/2-way pivoted armature valve

- Direct-acting, media-separated valve up to DN 4
- Pilot valve with Bürkert-specific flange variant (SFB)
- Maintenance-free pivoted armature technology
- Service-friendly, robust manual override
- Explosion-proof variants

Product variants described in the data sheet may differ from the product presentation and description.

### Can be combined with

	<p><b>Type 2518</b> Cable plug, form A according to DIN EN 175301-803</p>	▶
	<p><b>Type 1087</b> Timer, form A according to DIN EN 175301-803</p>	▶
	<p><b>Type 2509</b> Cable plug, form A according to DIN EN 175301-803</p>	▶

### Type description

The 0331 valve is a direct-acting, media-separated pivoted armature valve. It is available as a 2/2 and 3/2-way variant. As a 3/2-way variant, it can be used as a distributor or mixing valve. Various diaphragm materials and circuit functions are available depending on the actual application. Brass, stainless steel, PEEK and polypropylene bodies are offered. The solenoid coils are moulded with a chemically resistant epoxy. Since the coil system is separated from the medium by a diaphragm, the valve is especially suitable for critical media such as aggressive acids and lyes. The 0331 is equipped with manual override for start-up and testing. To reduce energy demands, all the coils can be delivered with electronic power reduction or as an impulse variant. The switching status can be indicated via position feedback as a binary or NAMUR signal.

## Table of contents

<b>1. General technical data</b>	<b>4</b>
<b>2. Circuit functions</b>	<b>6</b>
<b>3. Approvals and conformities</b>	<b>6</b>
3.1. General notes .....	6
3.2. Conformity .....	6
3.3. Standards .....	6
3.4. Explosion protection .....	7
3.5. North America (USA/Canada) .....	7
3.6. Others .....	7
DNV GL classification .....	7
<b>4. Materials</b>	<b>8</b>
4.1. Bürkert resistApp .....	8
4.2. Material specifications .....	8
<b>5. Dimensions</b>	<b>9</b>
5.1. Standard variant .....	9
Metal body .....	9
Plastic body .....	10
Cable variant .....	11
5.2. Explosion-proof variant .....	12
Terminal box variant .....	12
Cable variant .....	13
<b>6. Product connections</b>	<b>14</b>
6.1. Port connection .....	14
Pin assignment standard variant .....	14
Pin assignment explosion-proof variant .....	14
<b>7. Performance specifications</b>	<b>15</b>
7.1. Pressure range and flow rate .....	15
Standard variant .....	15
Explosion-proof variant .....	16
Use in other circuit function .....	16
<b>8. Product accessories</b>	<b>17</b>
8.1. Accessory standard variant .....	17
8.2. Accessory explosion-proof variant .....	18
8.3. Cable glands for ATEX/IECEX terminal box .....	18
8.4. Special tool to turn the terminal box .....	18
<b>9. Ordering information</b>	<b>19</b>
9.1. Bürkert eShop .....	19
9.2. Bürkert product filter .....	19
9.3. Bürkert Product Enquiry Form .....	19
9.4. Ordering chart .....	20
UL Recognized (UR) and CSA approval .....	20
Coil UL Listed (cULus) for hazardous locations, Class I, Division 2 .....	21

9.5.	Ordering chart accessories.....	22
	Cable plug Type 2518, form A according to DIN EN 175301 - 803 .....	22
	Cable plug Type 2509, form A according to DIN EN 175301 - 803.....	22
	Cable glands for ATEX/IECEX terminal box .....	22
	Circlip .....	23
	Manifolds for flange valves NPT 1/4.....	23
	Accessories for manifolds.....	23

## 1. General technical data

Product properties	
Dimensions	Further information can be found in chapter "5. Dimensions" on page 9.
<b>Material</b>	
Seal	EPDM FKM FFKM NBR
Body	Brass Stainless steel (1.4401/316) PP (Polypropylene) PEEK PVDF (on request)
Material resistance	Further information can be found in chapter "4.1. Bürkert resistApp" on page 8.
<b>Weight</b>	
Standard variant	Metal body: 1.04 lb Plastic body: 0.88 lb
Explosion-proof variant	Metal body: 1.65 lb Plastic body: 1.32 lb
Orifice	DN 2...DN 4
Circuit function	A, B, C, D, E, F and T Further information can be found in chapter "2. Circuit functions" on page 6.
Thermal insulation class of solenoid coil	Epoxy coil class H
Performance data	
<b>Duty cycle</b>	
With brass and stainless steel	100 % continuous operation
With PP and PVDF	40 % duty cycle (60 % intermittent operation) in 30 min for 8 W variant 100 % continuous operation for 5 W variant
With PEEK	60 % duty cycle (40 % intermittent operation) in 30 min for 8 W variant
With block mounting	Use reduced duty cycle or 5 W coil
Switching frequency (explosion-proof variant)	Medium temperature up to + 158 °F: max. 20/min Medium temperature up to + 194 °F: max. 5/min
<b>Switching time<sup>1)</sup> standard variant</b>	
Frequency AC	Opening: 8...15 ms Closing: 8...15 ms
Frequency DC	Opening: 10...20 ms Closing: 10...20 ms
<b>Switching time<sup>1)</sup> explosion-proof variant</b>	
Orifices 2...4	Opening: 30 ms Closing: 40 ms
Electrical data	
<b>Power consumption standard</b>	
Frequency AC	Inrush: 30 VA Hold: 15 VA Hold: 8 W
Frequency DC	Cold: 11 W Warm: 8 W
<b>Power consumption impulse (inrush winding)</b>	
Frequency AC	Hold: 20 VA Hold: 11 W
Frequency DC	Cold: 11 W Warm: 8 W
<b>Power consumption explosion-proof variant</b>	
Frequency AC/DC	Inrush: 40 W Hold: 3 W

**Voltage**

Standard variant	24 V 50 Hz, 110 V 50 Hz, 230 V 50 Hz, 120 V 60 Hz, 240 V 60 Hz, 12 V DC, 24 V DC (further voltages on request)
Explosion-proof variant	24 V, 230 V (further voltages on request)
Voltage tolerance	± 10 %

**Medium data**

**Operating medium**

With NBR	Neutral mediums such as compressed air, town gas, water, hydraulic oil, oils and greases without additives, oxygen
With EPDM	Alkalies, acids to medium concentrations, alkaline washing and bleaching lyes
With FKM	Oxidizing acids and substances, hot oils with additives, salt solutions, waste gases, oxygen
With FFKM	Aggressive mediums, hot air, hot oils
All Materials	Further information can be found in chapter <b>"4.1. Bürkert resistApp" on page 8</b>

**Medium temperature**

With body material brass, stainless steel or PEEK	NBR: + 32 °F...+ 176 °F EPDM: - 22 °F...+ 194 °F FKM: + 32 °F...+ 194 °F FFKM: + 41 °F...+ 194 °F
With body material PP	NBR: + 32 °F...+ 176 °F EPDM: - 22 °F...+ 176 °F FKM: + 32 °F...+ 176 °F FFKM: + 41 °F...+ 176 °F

Viscosity	Max. 37 cSt
-----------	-------------

**Product connections**

**Electrical connection**

Standard variant	<ul style="list-style-type: none"> <li>• Plug contacts according to DIN EN 175 301 - 803 form A for cable plug <b>Type 2518</b> ▶ Further information can be found in chapter <b>"Cable plug Type 2518, form A according to DIN EN 175301 - 803" on page 22.</b></li> <li>• Plug contacts according to DIN EN 175 301 - 803 form A for cable plug <b>Type 2509</b> ▶ (Also available with moulded cable on request.) Further information can be found in chapter <b>"Cable plug Type 2509, form A according to DIN EN 175301 - 803" on page 22.</b></li> </ul>
Explosion-proof variant	Moulded cable Terminal box without safety fuse (Information about ACP016 see operating manual.)
Port connection	Flange interface according to Bürkert standard (see also chapter <b>"5. Dimensions" on page 9</b> )

**Approvals and conformities**

**Degree of protection**

Standard variant	IP65 with cable plug
Explosion-proof variant	IP65
Explosion protection	Further information can be found in chapter <b>"3.4. Explosion protection" on page 7.</b>
North America (USA/Canada)	Further information can be found in chapter <b>"3.5. North America (USA/Canada)" on page 7.</b>
Others	Further information can be found in chapter <b>"3.6. Others" on page 7.</b>

**Environment and installation**

Installation position	As required, preferably with actuator upright
-----------------------	---

**Ambient temperature**

Standard variant	Max. + 131 °F
Explosion-proof variant	Max. + 131 °F

1.) Measurement at + 68 °F, 87 psi at the valve outlet, opening: pressure build-up 0...90 %, closing: pressure reduction 100...10 %

DTS 1000598016 EN Version: E Status: RL (released | freigegeben | valide) printed: 26.02.2026

## 2. Circuit functions

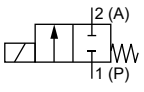
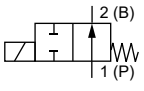
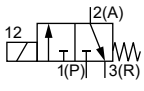
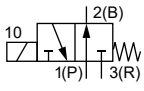
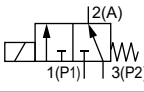
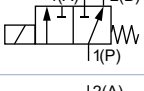
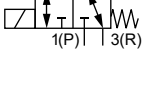
Symbol	Description
	<b>Circuit function A (CF A)</b> 2/2-way solenoid valve Direct-acting Normally closed
	<b>Circuit function B (CF B)</b> 2/2-way solenoid valve Direct-acting Normally open
	<b>Circuit function C (CF C)</b> 3/2-way solenoid valve Direct-acting Normally closed
	<b>Circuit function D (CF D)</b> 3/2-way solenoid valve Direct-acting Normally open
	<b>Circuit function E (CF E)</b> 3/2-way mixing valve (solenoid valve)
	<b>Circuit function F (CF F)</b> 3/2-way distribution valve (solenoid valve) Direct-acting
	<b>Circuit function T (CF T)</b> 3/2-way solenoid valve Direct-acting Flow direction optional Normally closed

## 3. Approvals and conformities

### 3.1. General notes

- The approvals and conformities listed below must be stated when making enquiries. This is the only way to ensure that the product complies with all required specifications.
- Not all available variants can be supplied with the below mentioned approvals or conformities.



### 3.2. Conformity

In accordance with the Declaration of Conformity, the product is compliant with the EU Directives.





### 3.3. Standards

The applied standards which are used to demonstrate compliance with the EU Directives are listed in the EU-Type Examination Certificate and/or the EU Declaration of Conformity.

### 3.4. Explosion protection

Approval	Description					
  	<p><b>Optional: Explosion protection according to category 2 (zone 1/21)</b></p> <p>Ex marking of the components according to the following table:</p>					
	<table border="1"> <thead> <tr> <th colspan="2">Coil Type ACP016</th> </tr> <tr> <th>Coils with cable outlet</th> <th>Coils with terminal box</th> </tr> </thead> <tbody> <tr> <td> <p><b>ATEX:</b></p> <p>EPS 16 ATEX 1 111 X                      II 2G Ex mb IIC T4 Gb                      II 2D Ex mb IIIC T130 °C Db</p> <p><b>IECEX:</b></p> <p>IECEX EPS 16.0049X                      Ex mb IIC T4 Gb                      Ex mb IIIC T130 °C Db</p> </td> <td> <p><b>ATEX:</b></p> <p>EPS 16 ATEX 1 111 X                      II 2G Ex eb mb IIC T4 Gb                      II 2D Ex mb tb IIIC T130 °C Db</p> <p><b>IECEX:</b></p> <p>IECEX EPS 16.0049X                      Ex eb mb IIC T4 Gb                      Ex mb tb IIIC T130 °C Db</p> </td> </tr> </tbody> </table>	Coil Type ACP016		Coils with cable outlet	Coils with terminal box	<p><b>ATEX:</b></p> <p>EPS 16 ATEX 1 111 X                      II 2G Ex mb IIC T4 Gb                      II 2D Ex mb IIIC T130 °C Db</p> <p><b>IECEX:</b></p> <p>IECEX EPS 16.0049X                      Ex mb IIC T4 Gb                      Ex mb IIIC T130 °C Db</p>
Coil Type ACP016						
Coils with cable outlet	Coils with terminal box					
<p><b>ATEX:</b></p> <p>EPS 16 ATEX 1 111 X                      II 2G Ex mb IIC T4 Gb                      II 2D Ex mb IIIC T130 °C Db</p> <p><b>IECEX:</b></p> <p>IECEX EPS 16.0049X                      Ex mb IIC T4 Gb                      Ex mb IIIC T130 °C Db</p>	<p><b>ATEX:</b></p> <p>EPS 16 ATEX 1 111 X                      II 2G Ex eb mb IIC T4 Gb                      II 2D Ex mb tb IIIC T130 °C Db</p> <p><b>IECEX:</b></p> <p>IECEX EPS 16.0049X                      Ex eb mb IIC T4 Gb                      Ex mb tb IIIC T130 °C Db</p>					

### 3.5. North America (USA/Canada)

Approval	Description
	<p><b>Optional (valid for coils): UL Hazardous Locations – Explosion Protection</b></p> <p>UL Listed for Hazardous Locations for USA and Canada                      Class I, Zone 1                      Class I, Division 2, Group A, B, C and D                      Class II + III, Division 2, Group F and G</p>
	<p><b>Optional (valid for valves): UL Recognized for the USA</b></p> <p>The valves are UL Recognized for the USA according to:</p> <ul style="list-style-type: none"> <li>UL 429 (electrically operated valves) and UL 429A (Electrically Operated Valves for Fire Protection Service)</li> </ul>
	<p><b>Optional (valid for valves): CSA for Canada</b></p> <p>The valves are CSA approved for Canada according to:</p> <ul style="list-style-type: none"> <li>CSA 139 (electrically operated valves)</li> </ul>
	<p><b>Optional (valid for coils): FM (Factory Mutual) – Explosion Protection</b></p> <p>FM for Hazardous Locations for USA and Canada                      Class I, Zone 1                      Class I, Division 1, Groups A, B, C and D                      Class II + III, Division 1, Groups E, F and G</p>

### 3.6. Others

#### DNV GL classification

Approval	Description
	<p><b>DNV GL classification – Ships, offshore units, and high speed and light craft</b></p> <p>The products are accepted for installation on all vessels classed by DNV GL.</p>

DTS 1000598016 EN Version: E Status: RL (released | freigegeben | valide) printed: 26.02.2026

## 4. Materials

### 4.1. Bürkert resistApp



#### Bürkert resistApp – Chemical resistance chart

You want to ensure the reliability and durability of the materials in your individual application case? Verify your combination of media and materials on our website or in our resistApp.

[Start chemical resistance check](#)

### 4.2. Material specifications

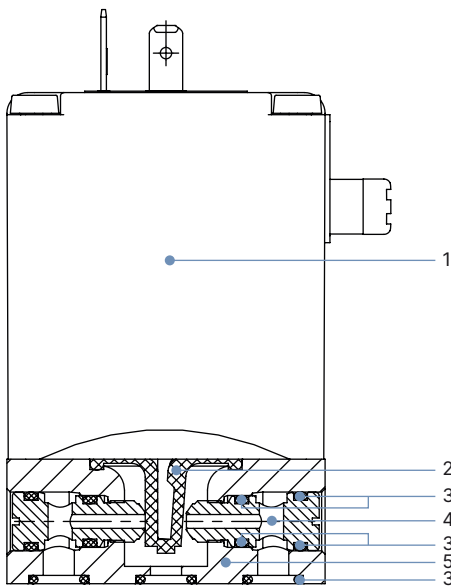

No.	Element	Material
1	Coil	Epoxy
2	Diaphragm	EDPM, FKM, FFKM, NBR
3	O-ring	EDPM, FKM, FFKM, NBR
4	Seat	Brass Stainless steel (1.4401/316) PP (Polypropylene) PEEK
5	Valve body	Brass Stainless steel (1.4401/316) PP (Polypropylene) PEEK

## 5. Dimensions

### 5.1. Standard variant

#### Metal body

**Note:**

- Dimensions in mm [inch]
- The dimensions of the cable plug Type 2518 can be found in chapter “Cable plug Type 2518, form A according to DIN EN 175301-803” on page 22.
- The dimensions of the cable plug Type 2509 can be found in chapter “Cable plug Type 2509, form A according to DIN EN 175301-803” on page 22.

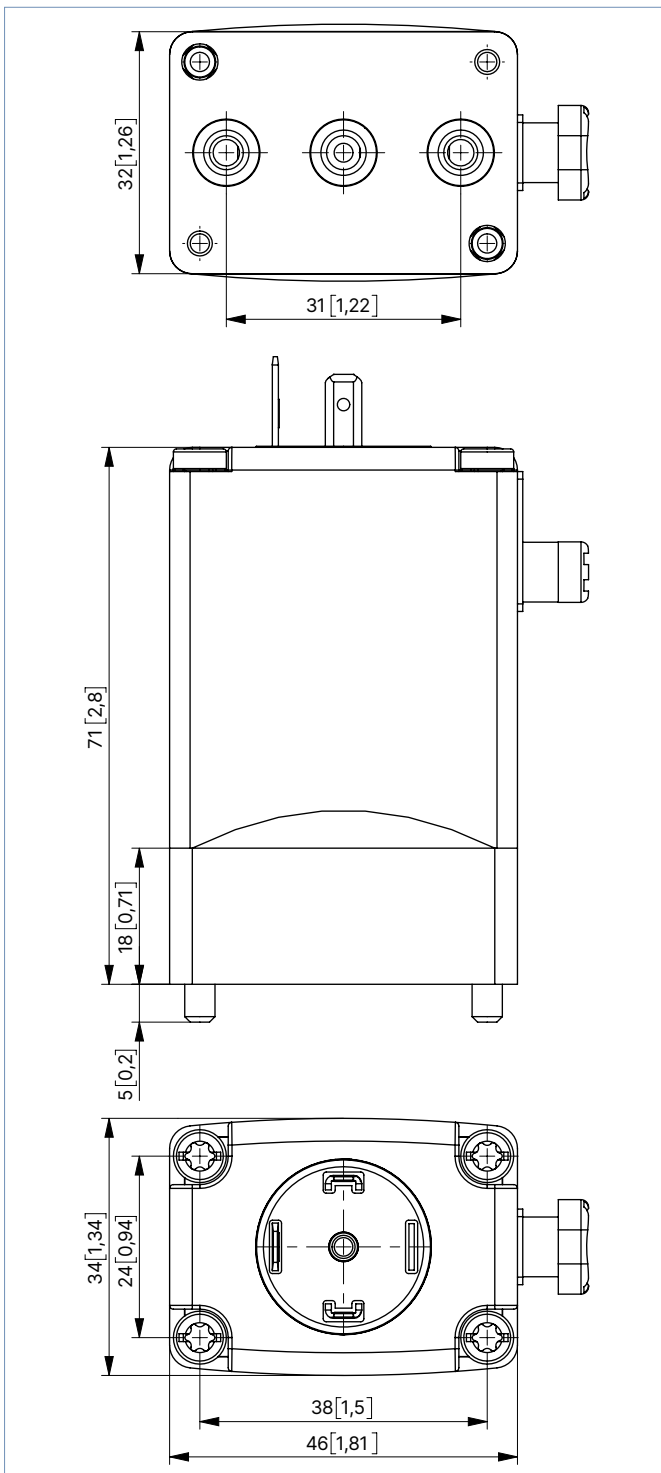

**Plastic body**

**Note:**

- Dimensions in mm [inch]
- The dimensions of the cable plug Type 2518 can be found in chapter “Cable plug Type 2518, form A according to DIN EN 175301 - 803” on page 22.
- The dimensions of the cable plug Type 2509 can be found in chapter “Cable plug Type 2509, form A according to DIN EN 175301 - 803” on page 22.

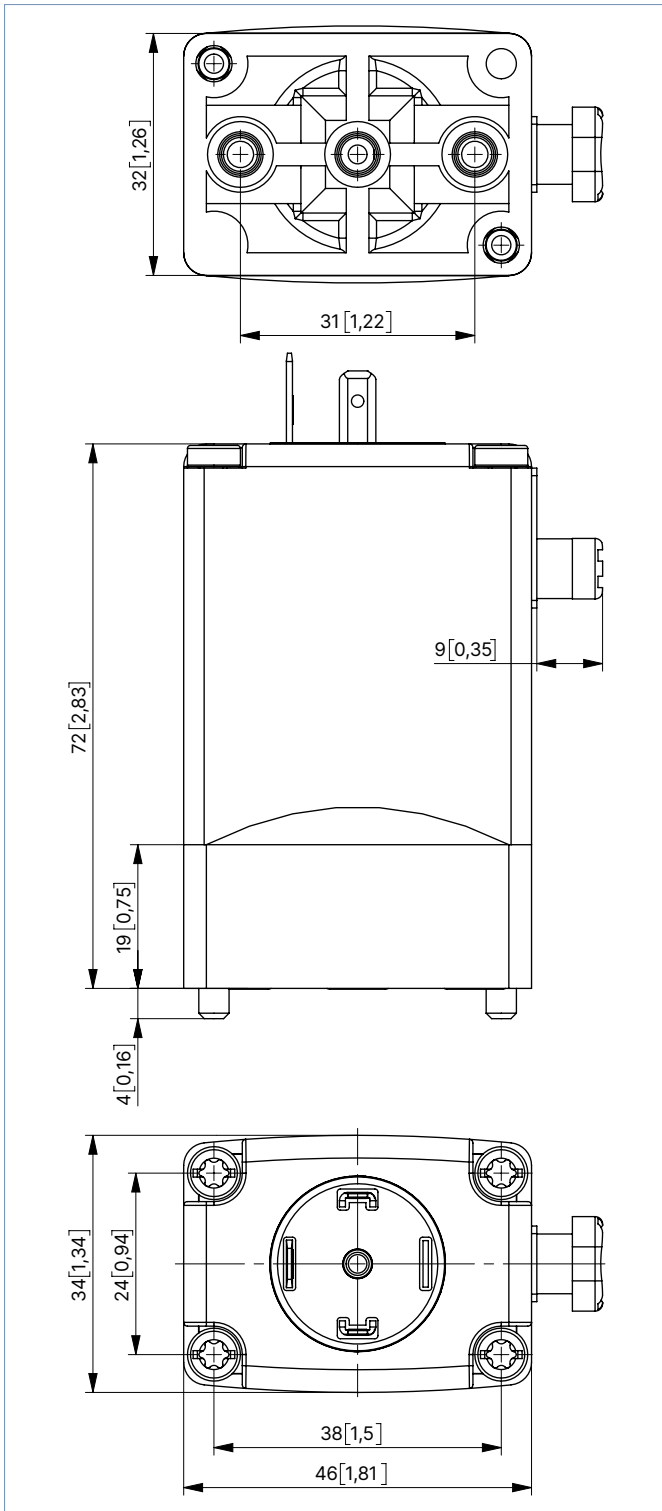

DTS 1000598016 EN Version: E Status: RL (released | freigegeben | valide) printed: 26.02.2026

**Cable variant**

**Note:**

Dimensions in mm [inch]

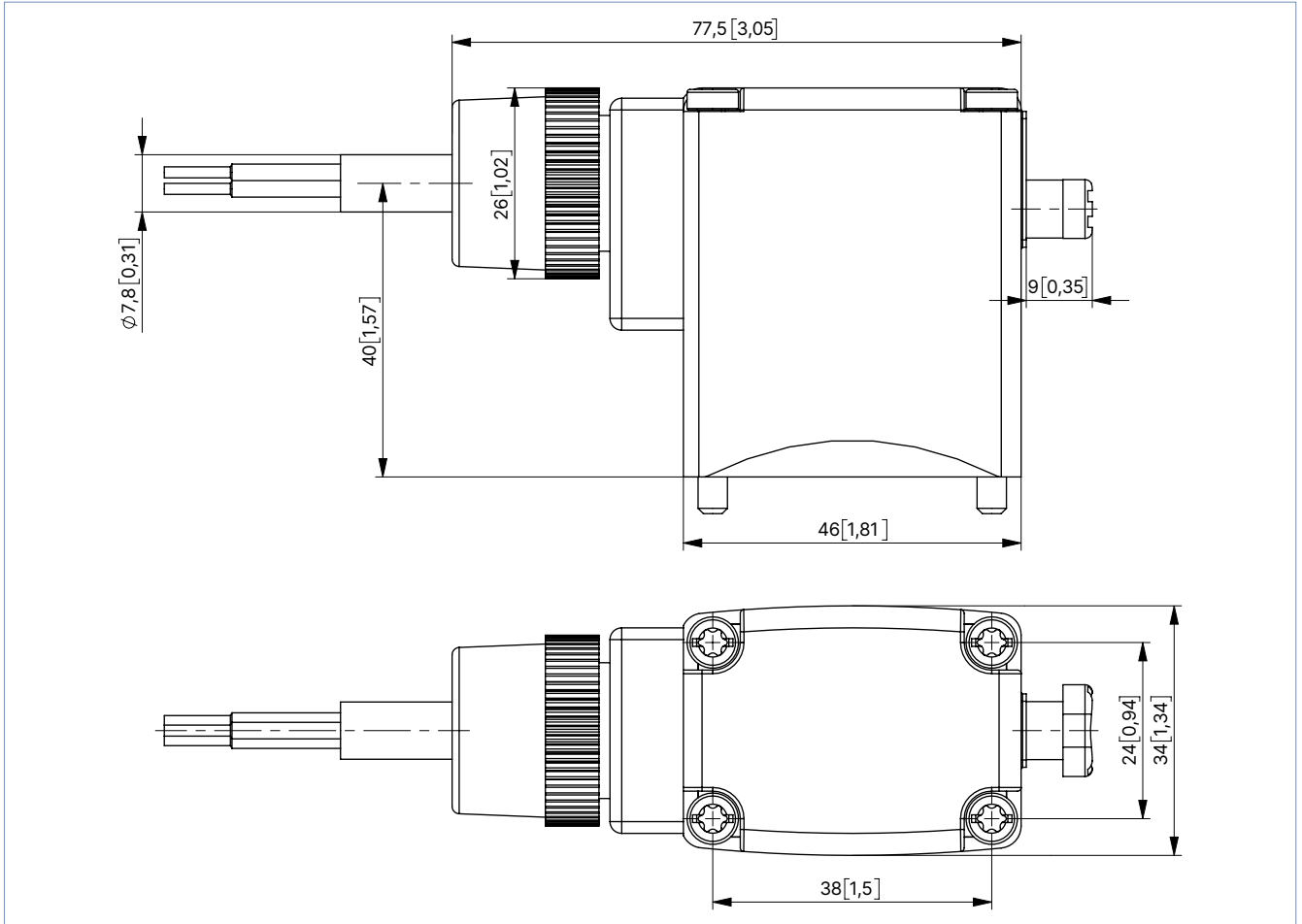

## 5.2. Explosion-proof variant

### Terminal box variant

**Note:**

Dimensions in mm [inch]

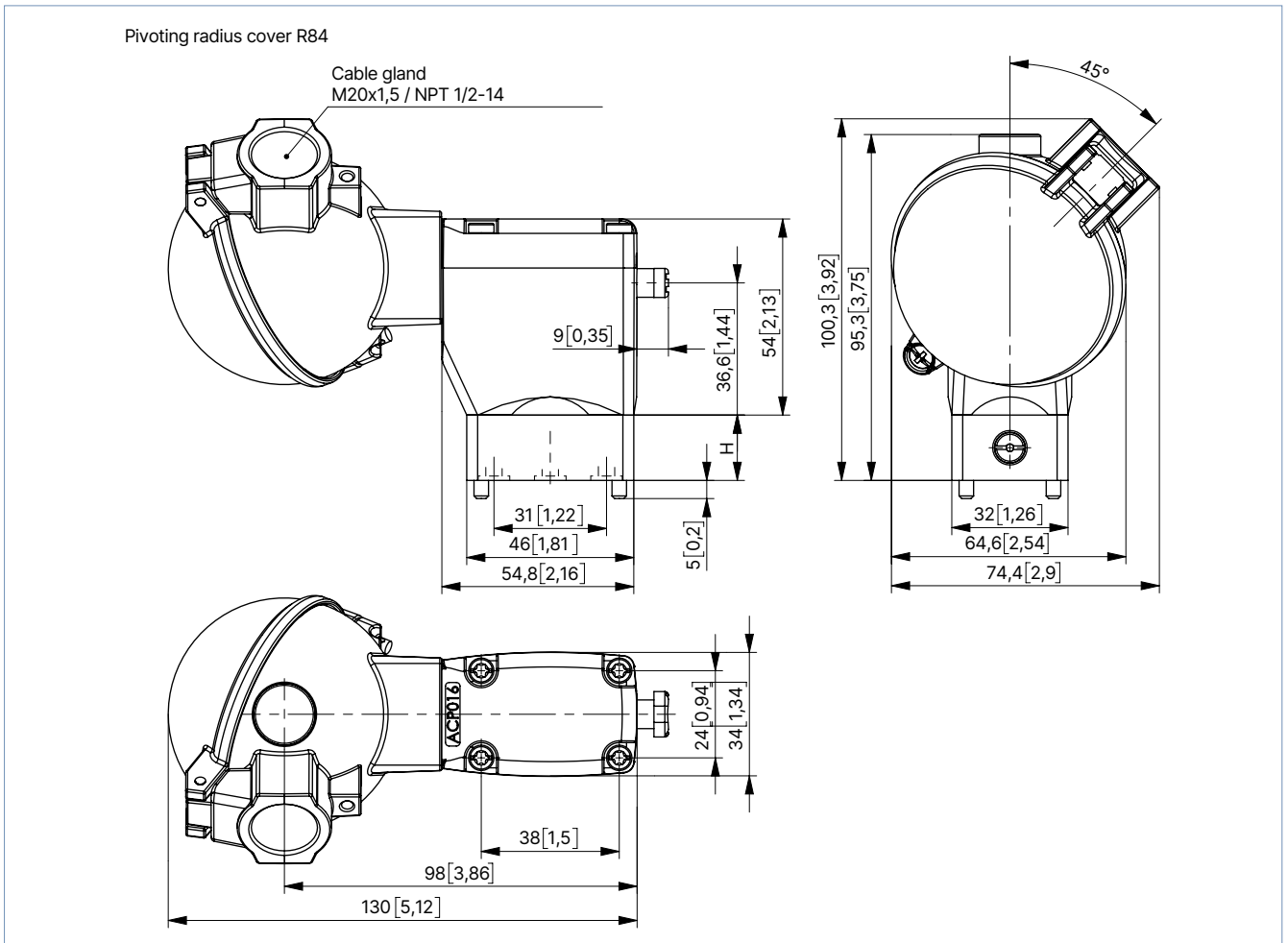

Body material	H	
	[mm]	[inch]
Brass/Stainless steel	18	
PP/PD	19	

**Cable variant**

**Note:**

Dimensions in mm [inch]

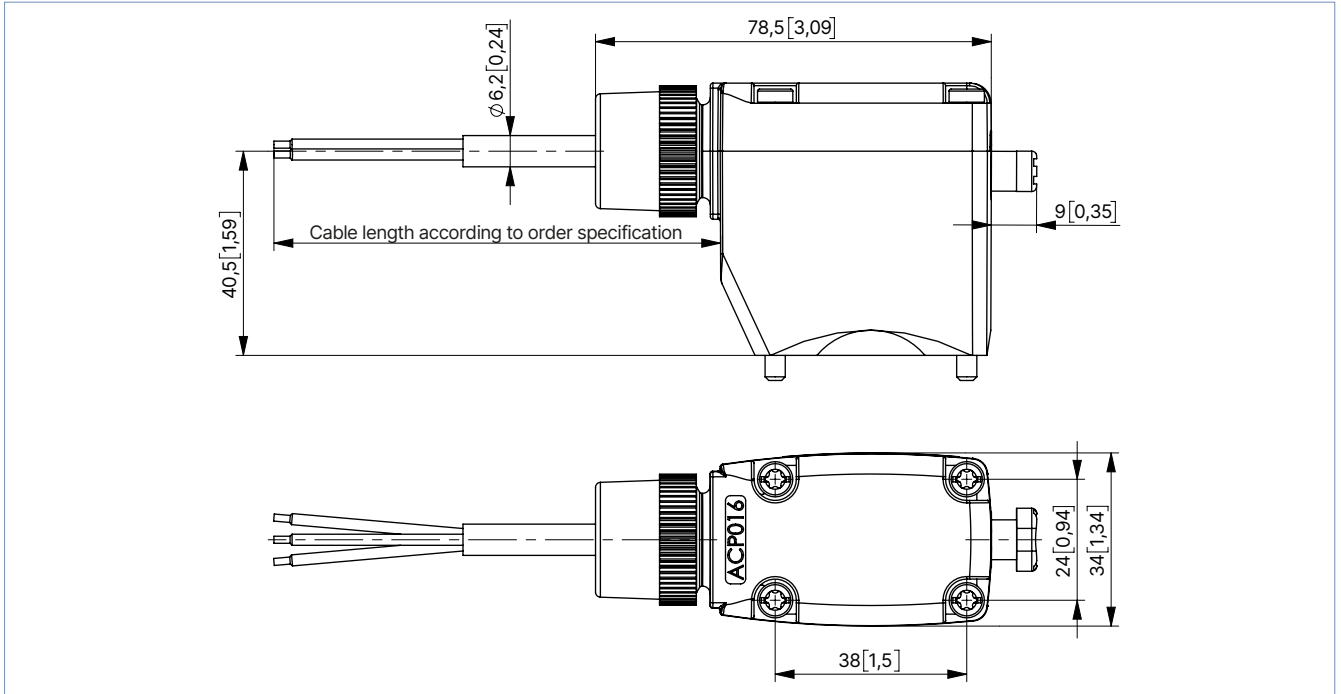

## 6. Product connections

### 6.1. Port connection

#### Pin assignment standard variant

**Note:**

- Dimensions in mm [inch]
- The pin assignment (marked No. 1, 2 and 3 in the drawing) depends on the circuit function. In the table, compare the respective pin assignment with the corresponding circuit function.

Circuit function	Connection 1	Connection 2	Connection 3	3-way
A	P	A	–	
B	–	B	P	
C	P	A	R	
D	R	B	P	
E	P1	A	P2	
F	A	P	B	
T	NC	I <sub>N</sub> /OUT	NO	

#### Pin assignment explosion-proof variant

**Note:**

The pin assignment (marked No. 1, 2 and 3 in the drawing) depends on the circuit function. In the table, compare the respective pin assignment with the corresponding circuit function.

Circuit function	Connection 1	Connection 2	Connection 3	3-way
A	P	A	–	
B	–	B	P	
C	P	A	R	
D	R	B	P	
E	P1	A	P2	
F	A	P	B	
T	NC	I <sub>N</sub> /OUT	NO	

DTS 1000598016 EN Version: E Status: RL (released | freigegeben | valide) printed: 26.02.2026

## 7. Performance specifications

### 7.1. Pressure range and flow rate

#### Standard variant

##### Note:

Refer to **"Use in other circuit function"** on page 16 for more information about use in other circuit function.

Circuit function	DN	C <sub>v</sub> value water <sup>1)</sup>		Pressure range <sup>2)</sup>		
		DC	AC (50 or 60 Hz)	Standard <sup>3)</sup>	Vacuum <sup>4)</sup>	Impulse <sup>5)</sup>
		[gal/min]	[gal/min]	[psi]	[psi]	[psi]
<b>Brass, stainless steel or PEEK body</b>						
A / B / C / D / F	2	0.09	0.12	0...232 <sup>6)</sup>	- 14...145	0...232 <sup>6)</sup>
	3	0.14	0.17	0...145	- 14...87	0...145
	4	0.17	0.21	0...73	- 14...44	0...73
E	2	0.09	0.12	0...145	- 14...116	0...145
	3	0.14	0.17	0...87	- 14...73	0...87
	4	0.17	0.21	0...44	- 14...36	0...44
T	2	0.09	0.12	0...174	- 14...116	–
	3	0.14	0.17	0...116	- 14...73	–
	4	0.17	0.21	0...58	- 14...44	–

Circuit function	DN	K <sub>v</sub> value water <sup>7)</sup>	Pressure range <sup>2)</sup>			
			Standard <sup>3)</sup> AC [50 or 60 Hz]	Standard <sup>3)</sup> DC	Vacuum <sup>4)</sup>	Impulse <sup>5)</sup>
			[gal/min]	[psi]	[psi]	[psi]
<b>PP and PVDF body</b>						
A / B / C / D / F	2	0.12	0...232 <sup>6)</sup>	0...174	- 14...145	0...174
	3	0.17	0...145	0...116	- 14...87	0...116
	4	0.21	0...73	0...58	- 14...44	0...58
E / T	2	0.12	0...145	0...102	- 14...102	0...102
	3	0.17	0...87	0...58	- 14...73	0...58
	4	0.21	0...44	0...36	- 14...36	0...29

1.) For frequency 56, the C<sub>v</sub> values of the DC variant apply

2.) Pressure data: overpressure to atmospheric pressure (deviating pressure range for 5 W variant)

3.) Heat output 8 W

4.) Vacuum possible for all seal materials

5.) Starting power 11 W

6.) The maximum medium pressure is 174 psi for seal material FKM and FFKM.

7.) The C<sub>v</sub> value at DC frequency is reduced by up to 10 % to guarantee the function.

**Explosion-proof variant**

**Note:**

Refer to **"Use in other circuit function"** on page 16 for more information about use in other circuit function.

Circuit function	DN	K <sub>v</sub> value water [gal/min]	Pressure range <sup>1,2,3)</sup> (MAWP <sup>3,3)</sup> )	
			Standard	Vacuum
			[psi]	[psi]
<b>Brass, stainless steel or PEEK body</b>				
A / B / C / D / F	2.0	0.12	0...232	- 14...145
	3.0	0.17	0...145	- 14...87
	4.0	0.21	0...73	- 14...44
E	2.0	0.12	0...145	- 14...116
	3.0	0.17	0...87	- 14...73
	4.0	0.21	0...44	- 14...36
T	2.0	0.12	0...145	- 14...116
	3.0	0.17	0...116	- 14...73
	4.0	0.21	0...58	- 14...44

- 1.) Devices with FKM and/or FFKM diaphragms are reduced to a maximum pressure of 174 psi.
- 2.) Pressure data: overpressure to atmospheric pressure
- 3.) Maximum allowable working pressure

Circuit function	DN	K <sub>v</sub> value water [gal/min]	Pressure range <sup>1,2,3)</sup> (MAWP <sup>3,3)</sup> )	
			Standard	Vacuum
			[psi]	[psi]
<b>PP and PVDF body</b>				
A / B / C / D / F	2.0	0.12	0...232	- 14...145
	3.0	0.17	0...145	- 14...87
	4.0	0.21	0...73	- 14...44
E / T	2.0	0.12	0...145	- 14...116
	3.0	0.17	0...87	- 14...73
	4.0	0.21	0...44	- 14...36

- 1.) Devices with FKM and/or FFKM diaphragms are reduced to a maximum pressure of 174 psi.
- 2.) Pressure data: overpressure to atmospheric pressure
- 3.) Maximum allowable working pressure

**Use in other circuit function**

The compression springs installed in the valves differ depending on the circuit function. When used in other circuit functions, the permissible operating pressure changes according to the following table.

**Note:**

The following table applies to both the standard variant and the explosion-proof variant.

Circuit function	Max. operating pressure [psi] when using the valve in a new circuit function																	
	Orifice DN 2						Orifice DN 3						Orifice DN 4					
	A <sup>1,)</sup>	B <sup>1,)</sup>	C	D	E	F	A	B	C	D	E	F	A	B	C	D	E	F
<b>Metal body (8 W respectively 11 W)</b>																		
C	232	22	232	22	22	232	145	15	145	15	15	145	73	12	73	12	12	73
D	58	232	65	232	58	58	36	145	36	145	29	44	29	73	29	73	29	29
T	116	116	145	145	145	116	87	87	87	87	87	87	44	44	44	44	44	44
<b>Plastic body (8 W respectively 11 W)</b>																		
C	232	22	232	22	22	232	145	15	145	15	15	145	73	12	73	12	12	73
D	58	232	65	232	58	58	36	145	36	145	29	44	29	73	29	73	29	29
F	232	22	145	22	22	232	87	15	87	15	15	145	58	15	58	15	15	-

1.) For circuit function A and B, the valve must be connected according to the pin assignment of 3/2-way valve.

DTS 1000598016 EN Version: E Status: RL (released | freigegeben | valide) printed: 26.02.2026

## 8. Product accessories

### 8.1. Accessory standard variant

Option	Variable code	Description
Impulse variant	CF02	Bistable magnetic system with inrush and drop-off coil; continuous operation or operation with short current pulses (min. 150 ms) possible
Oxygen variants	NL02	Suitable for applications with oxygen (non-metal materials that are in contact with the medium, are tested and approved according to BAM)
Increased purity requirements, e.g. oil-free, grease-free and silicone-free	NL50/ NL05	Wetted parts are specially cleaned and packaged in accordance with the valves
Increased tightness requirements	PCxx	Standard devices are tested at $10^{-2}$ mbar x l/s; up to $10^{-6}$ mbar is possible
Electrical feedback	LF02/ LF03	See <b>Type 1060</b> ▶. Function as opener, closer or toggle switch depending on the connection (no IP65 achievable)
High-performance electronics	CZ05	Inrush power 60 W, nominal holding current 3 W; with plastic variants 100 % duty cycle is now feasible
Vacuum variant	NA02	Suitable for vacuums up to - 14 psi
Increased purity and tightness requirements	NA03	Wetted parts are specially cleaned and leak tested to $10^{-4}$ mbar x l/sec
Increased purity and tightness requirements and vacuum variant	NA01	Wetted parts are specially cleaned and leak tested up to $10^{-4}$ mbar x l/sec and suited for vacuum up to - 14 psi
Coil with reduced power (5 W)	–	The devices have a lower pressure range; 100% duty cycle is possible with plastic variants
Cable plug	JHxx/ JGxx/ JFxx	A cable plug is part of the delivery. Cable plug variants (according to DIN EN 175301 - 803 form A), see separate data sheet <b>Type 2518</b> ▶ and <b>Type 2509</b> ▶
Manifold with banjo bolt	LG09	Due to the banjo bolt a direct attachment is possible (for example, to externally controlled pneumatic drives)
Approvals	PD01	CSA General Purpose valve
	PD02	UR (UL Recognized)/CSA approval
	PD07	DNV-GL (formerly Germanischer Lloyd)
	PR05	cFMus approved coil Class I, Division 1, Groups A, B, C and D - T4 Class II, Division 1, Groups E, F and G - T4 Class III, Division 1 - T4 Class I, Zone 1, AEx mb IIC T4 Gb, Zone 21 AEx mb IIIC T130 °C Db Ex mb IIC T4 Gb; Ex mb IIIC T130 °C Db
	PE95	UL (UL Listed) approval
	PU15	UL Listed for Hazardous Locations for USA and Canada, Class I, Zone 1, AEx eb mb IIC T4; Zone 21, AEx mb tb IIIC T130 °C / Class I, Div 2, Group A,B,C,D; Class II+III, Div 2, Group F,G
Possible conformities (depending on the assembly)	–	EAC, drinking water, FDA



### 8.2. Accessory explosion-proof variant

Option	Variable code	Description
Oxygen variants	NL02	Suitable for applications with oxygen (non-metal materials that are in contact with the medium, are tested and approved according to BAM)
Increased purity requirements, e.g. oil-free, grease-free and silicone-free	NL50/ NL05	Wetted parts are specially cleaned and packaged in accordance with the valves
Increased tightness requirements	PCxx	Standard devices are tested at $10^{-2}$ mbar x l/s; up to $10^{-6}$ mbar is possible
Vacuum variant	NA02	Suitable for vacuums up to - 14 psi
Increased purity and hermetic requirements	NA03	Wetted parts are specially cleaned and leak tested to $10^{-4}$ mbar x l/sec
Increased purity and hermetic requirements and vacuum variant	NA01	Wetted parts are specially cleaned and leak tested up to $10^{-4}$ mbar x l/sec and suited for vacuum up to - 14 psi
Electrical feedback	CF15	Coil with intrinsically safe proximity switches (PTB 00 ATEX 2048X) instead of manual override
Manifold with banjo bolt	LG09	Due to the banjo bolt a direct attachment is possible (for example, to externally controlled pneumatic drives)
Possible conformities (depending on the assembly)	-	EAC, drinking water, FDA

### 8.3. Cable glands for ATEX/IECEx terminal box

**Note:**

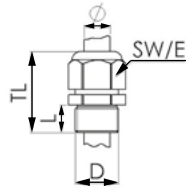
A polyamide cable gland is included in the scope of delivery. A nickel-plated brass variant can be ordered for a surcharge, see [“Cable glands for ATEX/IECEx terminal box” on page 22.](#)

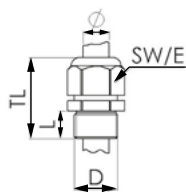
Description	Ex approvals		Dimensions										
	Certification	Identification											
Ex cable gland, nickel-plated brass, 6...13 mm 	PTB 04 ATEX 1112 X, IECEx PTB 13.0027X	II 2 G Ex e IIC Gb, II 2 D Ex tb IIIC Db IP68	 <table border="1"> <tr><td>TL</td><td>29...37 mm</td></tr> <tr><td>L</td><td>6 mm</td></tr> <tr><td>D</td><td>20 mm</td></tr> <tr><td>SW</td><td>24 mm</td></tr> <tr><td>E</td><td>27 mm</td></tr> </table>	TL	29...37 mm	L	6 mm	D	20 mm	SW	24 mm	E	27 mm
TL	29...37 mm												
L	6 mm												
D	20 mm												
SW	24 mm												
E	27 mm												
Ex cable gland, Polyamide, 7...13 mm 	PTB 13 ATEX 1015 X, IECEx PTB 13.0034X	II 2 G Ex e IIC Gb, II 2 D Ex tb IIIC Db IP68	 <table border="1"> <tr><td>TL</td><td>36...45 mm</td></tr> <tr><td>L</td><td>10 mm</td></tr> <tr><td>D</td><td>20 mm</td></tr> <tr><td>SW</td><td>24 mm</td></tr> <tr><td>E</td><td>28 mm</td></tr> </table>	TL	36...45 mm	L	10 mm	D	20 mm	SW	24 mm	E	28 mm
TL	36...45 mm												
L	10 mm												
D	20 mm												
SW	24 mm												
E	28 mm												

### 8.4. Special tool to turn the terminal box

**Note:**

This special tool is not included in the scope of delivery of the valve, see [“Cable glands for ATEX/IECEx terminal box” on page 22.](#)

Description	Components of the set
Set SC02-AC10 	<ul style="list-style-type: none"> <li>• Special tool</li> <li>• Service manual</li> </ul>

DTS 1000598016 EN Version: E Status: RL (released | freigegeben | valide) printed: 26.02.2026

## 9. Ordering information

### 9.1. Bürkert eShop



#### Bürkert eShop – Easy ordering and quick delivery

You want to find your desired Bürkert product or spare part quickly and order directly? Our online shop is available for you 24/7. Sign up and enjoy all the benefits.

[Order online now](#)

### 9.2. Bürkert product filter



#### Bürkert product filter – Get quickly to the right product

You want to select products comfortably based on your technical requirements? Use the Bürkert product filter and find suitable articles for your application quickly and easily.

[Try out our product filter](#)

### 9.3. Bürkert Product Enquiry Form

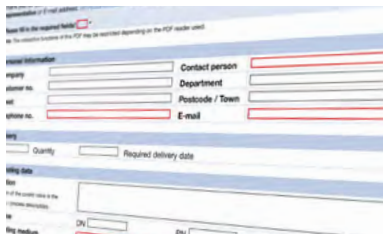

#### Bürkert Product Enquiry Form – Your enquiry quickly and compactly

Would you like to make a specific product enquiry based on your technical requirements? Use our Product Enquiry Form for this purpose. There you will find all the relevant information for your Bürkert contact. This will enable us to provide you with the best possible advice.

[Fill out the form now](#)

DTS 1000598016 EN Version: E Status: RL (released | freigegeben | valide) printed: 26.02.2026

9.4. Ordering chart

UL Recognized (UR) and CSA approval

Note:

Products with reduced delivery time

Circuit function	Orifice	Body and seat material	Seal material	Article no.			
				024/DC	024/60	120/60	240/60
	[mm]		[V/Hz]	[V/Hz]	[V/Hz]	[V/Hz]	
<b>With manual override and cable plug Type 2518</b>							
<b>CF A</b> 2/2-way solenoid valve Direct-acting Normally closed 	4.0	Polypropylene	FKM	o. r.	o. r.	o. r.	o. r.
<b>CF C</b> 3/2-way solenoid valve Direct-acting Normally closed 	2.0	Brass	NBR	453585 ☞	o. r.	453511 ☞	o. r.
	2.0	Stainless steel	FKM	451745 ☞	o. r.	451748 ☞	451750 ☞
	3.0	Brass	NBR	466262 ☞	o. r.	o. r.	o. r.
	3.0	Stainless steel	FKM	o. r.	o. r.	460133 ☞	o. r.
<b>CF D</b> 3/2-way solenoid valve Direct-acting Normally open 	2.0	Brass	NBR	453586 ☞	o. r.	o. r.	o. r.
	3.0	Brass	NBR	o. r.	o. r.	o. r.	o. r.
<b>CF E</b> 3/2-way mixing valve (solenoid valve) 	2.0	Brass	NBR	o. r.	o. r.	o. r.	o. r.
	3.0	Brass	NBR	o. r.	o. r.	o. r.	o. r.
	3.0	Polypropylene	EPDM	o. r.	o. r.	o. r.	o. r.
<b>CF T</b> 3/2-way solenoid valve Direct-acting Flow direction optional Normally closed 	2.0	Brass	FKM	o. r.	o. r.	o. r.	o. r.
	3.0	Brass	FKM	o. r.	o. r.	o. r.	o. r.
<b>With manual override and cable plug Type 2518 and manifold (banjo variant)</b>							
<b>CF C</b> 3/2-way solenoid valve Direct-acting Normally closed 	2.0	Brass	NBR	o. r.	o. r.	o. r.	o. r.
	3.0	Brass	NBR	o. r.	o. r.	o. r.	o. r.
	3.0	Brass	FKM	o. r.	o. r.	o. r.	o. r.

DTS 1000598016 EN Version: E Status: RL (released | freigegeben | valide) printed: 26.02.2026

Circuit function	Orifice	Body and seat material	Seal material	Article no.			
				024/DC	024/60	120/60	240/60
	[mm]			[V/Hz]	[V/Hz]	[V/Hz]	[V/Hz]
<b>CF E</b> 3/2-way mixing valve (solenoid valve)  	2.0	Brass	NBR	o. r.	o. r.	o. r.	o. r.

o. r. = on request

**Coil UL Listed (cULus) for hazardous locations, Class I, Division 2**

**Note:**

Other variants are available on request.

Circuit function	Orifice	Body and seat material	Seal material	Electrical connection	Article no.		
					024 / AC/DC	120/60	240/60
	[mm]				[V/Hz]	[V/Hz]	[V/Hz]
<b>With manual override</b>							
<b>CF A</b> 2/2-way solenoid valve Direct-acting Normally closed  	3.0	Stainless steel	FKM	Cable	o. r.	o. r.	o. r.
<b>CF C</b> 3/2-way solenoid valve Direct-acting Normally closed  	2.0	Stainless steel	NBR	Terminal box	o. r.	o. r.	o. r.
	2.0	Stainless steel	FKM	Terminal box	o. r.	o. r.	o. r.
	2.0	Stainless steel	NBR	Cable	o. r.	o. r.	o. r.
	3.0	Brass	NBR	Cable	o. r.	o. r.	o. r.
<b>CF D</b> 3/2-way solenoid valve Direct-acting Normally open  	3.0	Stainless steel	FKM	Cable	o. r.	394662 𐀀	o. r.
	2.0	Brass	NBR	Terminal box	o. r.	o. r.	o. r.
	2.0	Brass	NBR	Cable	o. r.	o. r.	o. r.
	2.0	Stainless steel	NBR	Cable	o. r.	o. r.	o. r.
	2.0	Stainless steel	NBR	Terminal box	o. r.	o. r.	o. r.
<b>CF T</b> 3/2-way solenoid valve Direct-acting Flow direction optional Normally closed  	2.0	Brass	NBR	Cable	o. r.	o. r.	o. r.
	2.0	Stainless steel	NBR	Terminal box	o. r.	o. r.	o. r.
	2.0	Stainless steel	FKM	Cable	o. r.	o. r.	o. r.
	2.0	Stainless steel	FKM	Terminal box	20023738 𐀀	o. r.	o. r.
	2.0	Stainless steel	NBR	Cable	o. r.	o. r.	o. r.
	2.0	Stainless steel	EPDM	Terminal box	o. r.	o. r.	o. r.
	2.0	Brass	NBR	Cable	o. r.	393077 𐀀	o. r.
	2.0	Brass	NBR	Terminal box	o. r.	o. r.	o. r.
	2.0	Brass	FKM	Cable	o. r.	20040892 𐀀	o. r.
2.0	Brass	FKM	Terminal box	o. r.	o. r.	o. r.	

o. r. = on request

DTS 1000598016 EN Version: E Status: RL (released | freigegeben | valide) printed: 26.02.2026

### 9.5. Ordering chart accessories

#### Cable plug Type 2518, form A according to DIN EN 175301 - 803

**Note:**

- Dimensions in mm
- For further variants see data sheet [Type 2518](#) ▶

Cable plug	Dimensions	Variant	Voltage	Article no.
		Without wiring (AC/DC)	0...250 V AC/DC	314802 𐀀
		With LED (AC/DC)	12...24 V AC/DC	314812 𐀀
		With LED and varistor (AC/DC)	12...24 V AC/DC	314820 𐀀
		With rectifier, LED and varistor	12...24 V AC/DC	314816 𐀀

#### Cable plug Type 2509, form A according to DIN EN 175301 - 803

**Note:**

- Dimensions in mm
- Without wiring (standard)
- The cable plug Type 2509 meets the requirements of UL hazloc Div. 2.
- The cable plug Type 2509 meets the requirements of UL Listed (UL 429) in assembly with a Bürkert solenoid valve.
- Refer to data sheet [Type 2509](#) ▶ for more information about the cable plug.

Cable plug	Dimensions	Variant	Voltage	Article no.
		Without wiring	0...250 V AC/DC	137943 𐀀

#### Cable glands for ATEX/IECEx terminal box

**Note:**

- A polyamide cable gland is included in the scope of delivery. A nickel-plated brass variant can be ordered for a surcharge.
- Refer to [“8.3. Cable glands for ATEX/IECEx terminal box” on page 18](#) for more information about Ex cable glands.
- Refer to [“8.4. Special tool to turn the terminal box” on page 18](#) for more information about special tool.

Description	Article no.
Ex cable gland, nickel-plated brass, 6...13 mm <sup>1)</sup>	773278 𐀀
Ex cable gland, polyamide, 7...13 mm <sup>1)</sup>	773277 𐀀
Set SC02-AC10: special tool <sup>2)</sup> incl. service manual	293488 𐀀

1.) Cable diameter

2.) Not included in the scope of delivery of the valve

**Circlip**

Description	Article no.
Circlip to prevent inadvertent manual actuation	013372

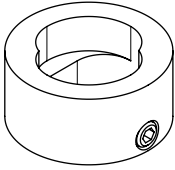

**Manifolds for flange valves NPT 1/4**

Number of valve slots	Length A		Hole spacing B		Article no.		
	[mm]	[inch]	[mm]	[inch]	Anodized Aluminium	Stainless steel	Brass
1	32	1.26	-	-	613983	o. r.	o. r.
2	69	2.72	-	-	006110	o. r.	o. r.
3	106	4.17	37	1.46	613706	o. r.	o. r.
4	143	5.63	74	2.91	006111	o. r.	o. r.
5	180	7.09	111	4.37	613704	o. r.	o. r.
6	217	8.54	148	5.83	613703	o. r.	o. r.
7	254	10	185	7.28	o. r.	o. r.	o. r.
8	291	11.46	222	8.74	o. r.	o. r.	-

o. r. = on request  
 - = not available

**Note:**

Dimensions in mm [inch]

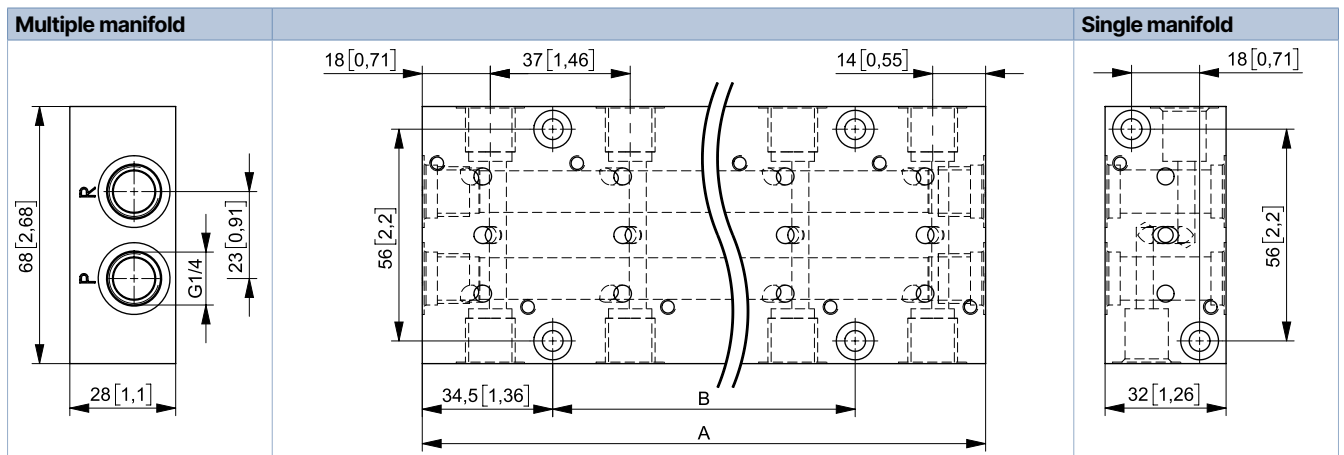

**Accessories for manifolds**

Description	Material	Seal material	Article no.
Cover plate (for unoccupied valve slot)	Stainless steel	FKM	265294
Cover plate (for unoccupied valve slot)	Anodized Aluminium	NBR	005625
Nipple (for connecting the collection channel of 2 manifolds)	Coated Steel	FKM	005049
Nipple (for connecting the collection channel of 2 manifolds)	Stainless steel	FKM	007376
Nipple (for connecting 2 manifolds; collection channel is closed)	Coated Steel	NBR	006049

DTS 1000598016 EN Version: E Status: RL (released | freigegeben | valide) printed: 26.02.2026