



## Positive displacement sensor fitting for continuous flow measurement

- DN15 to DN100
- INLINE Quarter-Turn technology
- Electronics available for indication, monitoring, transmitting, On/Off control and batch control

Type S070 can be combined for...



**Type 8070**

Positive displacement flowmeter



**Type 8072**

Positive displacement flowmeter



**Type 8075**

Positive displacement flowmeter



**Type 8076**

Positive displacement flowmeter

This positive displacement sensor fitting is specially designed for flow measurement and/or batch control of highly viscous fluids like glue, honey or oil.

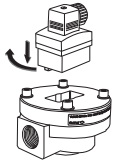

This measuring element must be associated to an electronic module SE30, SE32, SE35, SE36 with hall sensor principle only, quickly and easily connected together by a Quarter-Turn.

The design of this fitting is based on the oval rotor principle. This has proven to be a reliable and highly accurate volumetric method of measuring flow. Exceptional repeatability and high accuracy over a wide range of viscosities and flowrates are features of that design. The low pressure drop and high pressure rating make it suitable for both gravity and pump (in-line) applications.

General data	
<b>Compatibility</b>	With electronic SE30, SE32, SE35, SE36 with Hall sensor principle (see separate data sheet)
<b>Wetted parts materials</b>	
Body	Aluminium, stainless steel (316F)
Rotor	PPS, aluminium, stainless steel (316F)
Shaft	Stainless steel (316F)
Seal	FKM or FEP/PTFE encapsulated
Environment	
<b>Ambient temperature</b>	0 to 60°C (32 to 140°F) (operation and storage)
Standards, directives and approvals	
<b>Protection class</b>	IP66 (NEMA 6)
<b>Directives</b>	
Pressure	Complying with article 3 of §3 from 97/23/CE directive*. (without CE mark)

\* For the 97/23/CE pressure directive, the device can only be used under following conditions (dependent on max. pressure, pipe diameter and fluid).

Type of fluid	Conditions
Fluid group 1, §1.3.a	Forbidden
Fluid group 2, §1.3.a	DN ≤ 32, or DN > 32 and PN*DN ≤ 1000
Fluid group 1, §1.3.b	PN*DN ≤ 2000
Fluid group 2, §1.3.b	DN ≤ 200

Complete device data	
<b>Pipe diameter</b>	DN15 to DN100
Thread connection	1/2"; 1"; 1 1/2"; 2"; 3" (G or NPT)
Flange connection	25; 40; 50; 80 or 100 mm DIN PN16 flange 1"; 1 1/2"; 2"; 3" or 4" ANSI 150LB flange
<b>Measuring range</b>	
Viscosity > 5 cps	2 to 1200 l/min (0.53 to 320 gpm)
Viscosity < 5 cps	3 to 616 l/min (0.78 to 160 gpm)
<b>Medium temperature max.</b>	Aluminium body: 80°C (176°F) Stainless steel body: 120°C (248°F)
<b>Medium pressure max.</b>	
DN15	55 bar (798.05 PSI) (threaded process connection)
DN25	55 bar (798.05 PSI) <sup>1)</sup>
DN40/DN50	18 bar (261.18 PSI)
DN80	12 bar (174.12 PSI)
DN100	10 bar (145.1 PSI)
<b>Viscosity</b>	1000 cps. max. (higher on request)
<b>Max. particle size</b>	250 µm - To prevent damage from dirt or foreign matter, we strongly recommend the installation of a 250 µm strainer as close as possible to the inlet side of the meter.
<b>Accuracy</b>	±0.5% of Reading
<b>Repeatability</b>	±0.03% of Reading

<sup>1)</sup> or in accordance to the value of the used flanges

**Installation and operation**

The sensor fitting can be installed in any orientation as long as **the rotor shafts are always in a horizontal plane** (see figures to the right) and **the flow of the fluid is in the direction of the arrow marked on the body.**

The pipe must be filled with liquid and free from air bubbles. Avoid air purge of the system which would cause damages and to prevent damage from dirt or foreign matter, we strongly recommend the installation of a 250 µm strainer as close as possible to the inlet side of the meter.

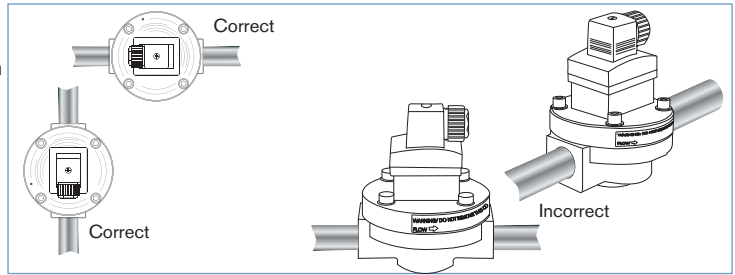

When fluid passes through the fitting, rotors turn. This rotation produces a measuring frequency in the associated hall sensor, which is proportional to the flow.

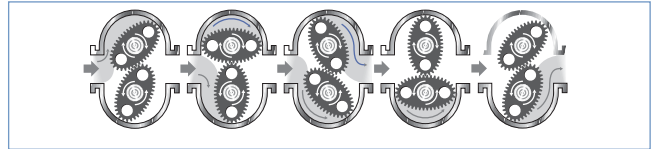

**Dimensions [mm]**

**Threaded connection**

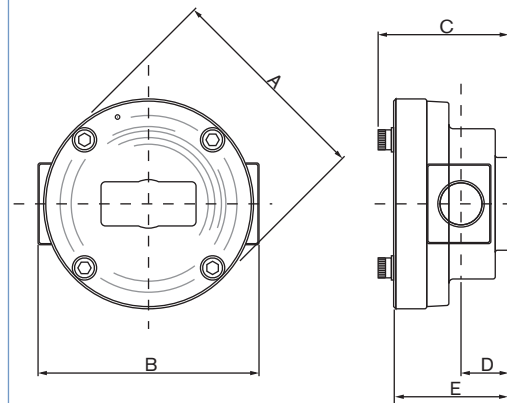

Orifice DN	A	B		C	D	E
		Stainless steel	Aluminium			
15	96	100	100	61	20	55
25	112	143	133	91	35	85
40	144	124	124	120	45	112
50	178	210	210	150	55	140
80	220	260	302	212	77	202

**Flanged connection**

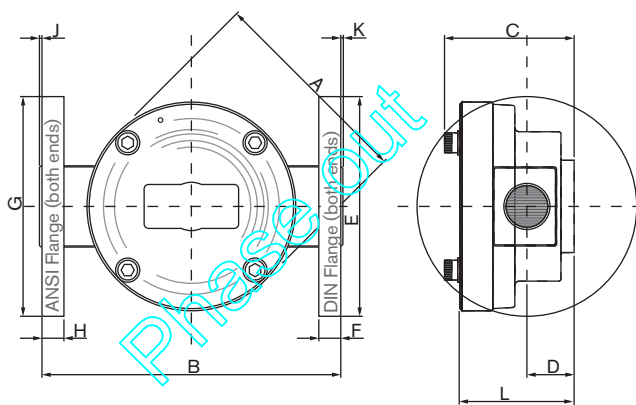

Orifice DN	A	B		C	D	E	F	G	H	J	K	L		
		Stainless Steel DIN	Stainless Steel ANSI										Al. DIN	Al. ANSI
25	112	291	294	281	284	91	35	115	16	108	16.0	1.6	1.6	85
40	144	262	270	262	270	120	45	150	16	127	17.5	1.6	1.6	112
50	178	264	264	264	264	150	55	165	18	152	19.0	1.6	1.6	140
80	220	344	348	436	436	212	77	200	22	191	22.5	1.6	1.6	202
100	291	382	390	578	578	230	108	220	22	229	22.5	1.6	1.6	234

## Ordering chart for sensor fitting Type S070

Orifice DN	Process connection	Flow Range		Body material	Rotor material	Seal	Item no.
		> 5 cps	< 5 cps				
15	G 1/2"	2 - 30 l/min	3 - 25 l/min	Aluminium	PPS	FKM	443 985
				Stainless steel	Stainless steel	FEP/PTFE	443 990
	NPT 1/2"	2 - 30 l/min	3 - 25 l/min	Aluminium	PPS	FKM	443 995
				Stainless steel	Stainless steel	FEP/PTFE	444 000
25	G 1"	6 - 120 l/min	10 - 100 l/min	Aluminium	PPS	FKM	443 986
				Stainless steel	Stainless steel	FEP/PTFE	443 991
	NPT 1"	6 - 120 l/min	10 - 100 l/min	Aluminium	PPS	FKM	443 996
				Stainless steel	Stainless steel	FEP/PTFE	444 001
	25 mm DIN PN16 flange	6 - 120 l/min	10 - 100 l/min	Aluminium	PPS	FKM	553 637
				Stainless steel	Stainless steel	FEP/PTFE	553 634
	1" ANSI 150 LB flange	6 - 120 l/min	10 - 100 l/min	Aluminium	PPS	FKM	553 636
				Stainless steel	Stainless steel	FEP/PTFE	553 633
40	G 1 1/2"	10 - 250 l/min	15 - 235 l/min	Aluminium	PPS	FKM	443 987
				Stainless steel	Stainless steel	FEP/PTFE	443 992
	NPT 1 1/2"	10 - 250 l/min	15 - 235 l/min	Aluminium	PPS	FKM	443 997
				Stainless steel	Stainless steel	FEP/PTFE	444 002
	40 mm DIN PN16 flange	10 - 250 l/min	15 - 235 l/min	Aluminium	PPS	FKM	443 988
				Stainless steel	Stainless steel	FEP/PTFE	443 993
	1 1/2" ANSI 150 LB flange	10 - 250 l/min	15 - 235 l/min	Aluminium	PPS	FKM	443 998
				Stainless steel	Stainless steel	FEP/PTFE	444 003
50	G 2"	15 - 350 l/min	30 - 300 l/min	Aluminium	PPS	FKM	553 640
				Aluminium	PPS	FKM	553 641
	50 mm DIN PN16 flange	15 - 350 l/min	30 - 300 l/min	Aluminium	PPS	FKM	443 989
				Stainless steel	Stainless steel	FEP/PTFE	443 994
	2" ANSI 150 LB flange	15 - 350 l/min	30 - 300 l/min	Aluminium	PPS	FKM	443 999
				Stainless steel	Stainless steel	FEP/PTFE	444 004
80	G 3"	20 - 733 l/min	66 - 616 l/min	Aluminium	Aluminium	FKM	553 642
				Aluminium	Aluminium	FKM	553 643
	80 mm DIN PN16 flange	20 - 733 l/min	66 - 616 l/min	Aluminium	Aluminium	FKM	553 645
				Aluminium	Aluminium	FKM	553 644
	3" ANSI 150 LB flange	20 - 733 l/min	66 - 616 l/min	Aluminium	Aluminium	FKM	553 644
100	100 mm DIN PN16 flange	120 - 1200 l/min	---	Aluminium	Aluminium	FKM	553 647
	4" ANSI 150 LB flange	120 - 1200 l/min	---	Aluminium	Aluminium	FKM	553 646

## Ordering chart for spare parts for sensor fitting S070

Description	Orifice Size		Materials	Item no.
	[mm]	[inch]		
Rotor	DN15	1/2"	PPS	550 933
			Stainless steel	550 934
	DN25	1"	PPS	550 937
			Stainless steel	550 938
	DN40	1 1/2"	PPS	550 941
			Stainless steel	550 942
DN50	2"	PPS	550 945	
		Stainless steel	550 946	

Description	Orifice Size		Materials	Item no.
	[mm]	[inch]		
O-ring	DN15	1/2"	FEP/PTFE	550 929
			FKM	550 930
	DN25	1"	FEP/PTFE	550 935
			FKM	550 936
	DN40	1 1/2"	FEP/PTFE	550 939
			FKM	550 940
	DN50	2"	FEP/PTFE	550 943
			FKM	550 944

Interconnection possibilities with other Bürkert products

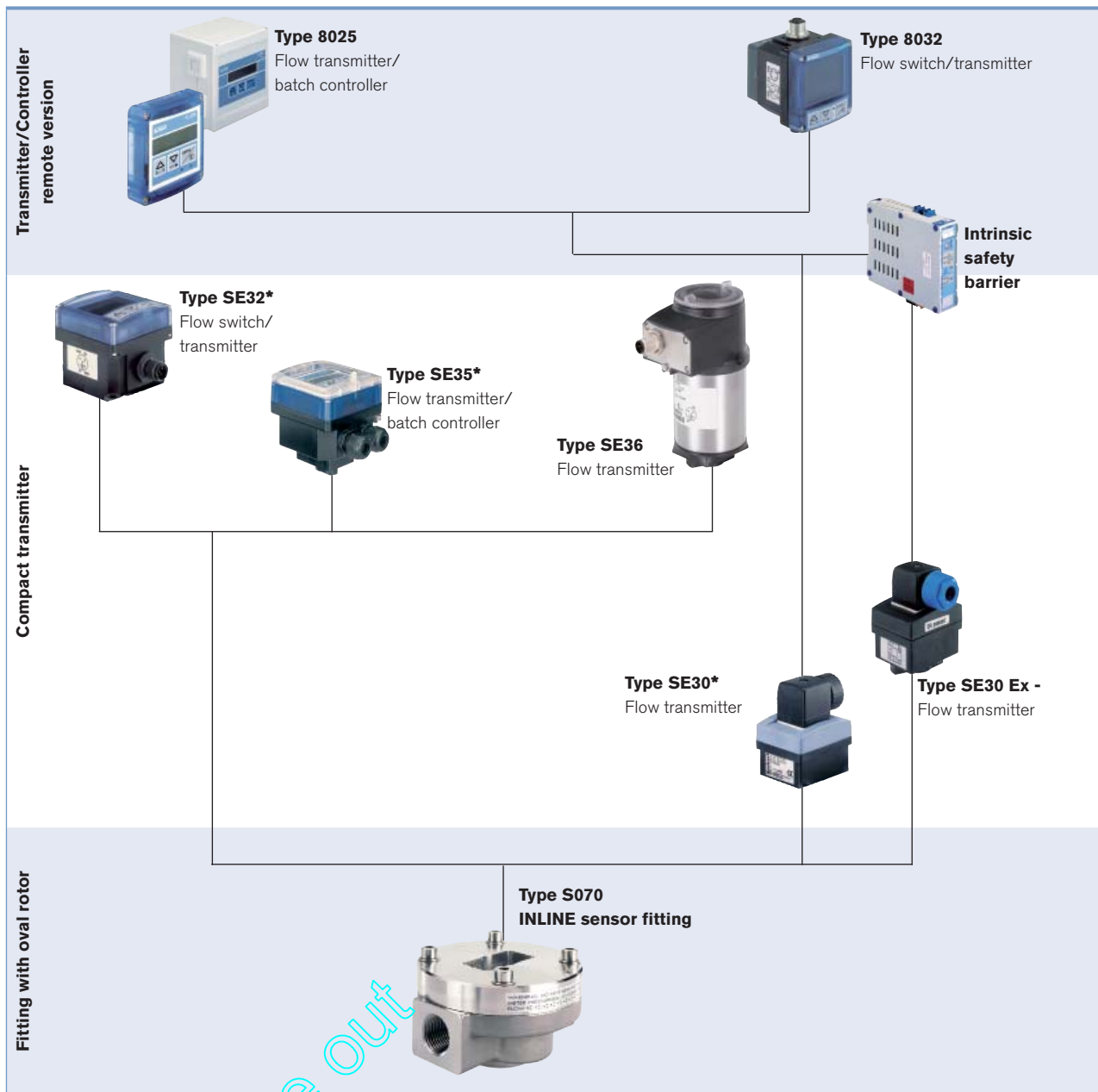

\* Use only version with Hall transducer

Phase out

DTS 100001140 EN Version: O Status: PO (Phase out) | Phase out | printed: 28.08.2020

To find your nearest Bürkert office, click on the orange box →

[www.burkert.com](http://www.burkert.com)

In case of special application conditions, please consult for advice.

Subject to alteration.  
© Christian Bürkert GmbH & Co. KG

1605/8\_EU-en\_00891837