

Positive displacement flowmeter



- Configurable outputs: one or two transistor output(s) and single or dual 4...20 mA current output(s)
- Removable backlit display of flow rate and/or 2 two totalized volumes
- Automatic-calibration: Teach-In, simulation of outputs signals provided without the need for real flow

Type 8076 can be combined with...



Type 6213
Solenoid valve



Type 8619
multiCELL
transmitter/controller



Type 8611
eCONTROL
Universal controller



Type 2101 (8692)
Continuous
TopControl system



Type 2030
On/Off Diaphragm
valve

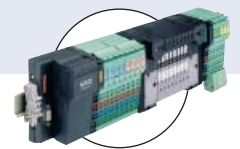

Type 8644
Valve islands

This positive displacement flowmeter with display Type 8076 is designed for use in highly viscous fluid like glue, honey. It is made up of a compact sensor fitting (S070) and an enclosure with cover, containing the electronic module. A removable display completes the flowmeter. This ensemble (SE36) is quickly and easily connected to the sensor fitting (S070) by a Quarter-Turn.

The flowmeter can operate without the display, but it will be required for configuring the flowmeter (i.e. set parameters, restore default parameters, configure information to be displayed, programme access code, adjust 4...20 mA output(s)...) and also for visualizing continuously the measured and processed data.

The device Type 8076 is available with:

- 2 configurable outputs: one transistor output (NPN) and one 4...20 mA current output (2-wire)
- 3 configurable outputs: two transistor outputs (NPN/PNP) and one 4...20 mA current output (2-wire)
- 4 configurable outputs: two transistor outputs (NPN/PNP) and two 4...20 mA current outputs (3-wire)

The device Type 8076 converts the measured signal, displays different values in different units (if display mounted) and computes the output signals, which are provided via one or two M12 fixed connectors. Thanks to 1 or 2 transistor outputs, the flowmeter can be used to switch a solenoid valve, activate an alarm and, thanks to 1 or 2 current outputs, establish one or two control loops.

General data

Compatibility

With INLINE sensor fittings S070 (see corresponding data sheet)

Materials

Housing	See exploded view, on next page
Cover	Stainless steel 1.4561, PPS
Seals	PC
Screws	EPDM
Fixed connector mounting plate	Stainless steel
Fixed connector	Stainless steel 1.4404 (316L)
Display	Brass nickel plated (stainless steel on request)
Navigation key	PC
Quarter-Turn system	PBT
Wetted parts materials	PC
Sensor fitting body	Aluminium or stainless steel (316L/1.4401)
Rotor	PPS, Aluminium or stainless steel (316L/1.4401)
Shaft	Stainless steel
Seal	FKM or FEP/PTFE

Display

Grey dot matrix 128 x 64 with backlighting

Electrical connections

2 or 3 outputs flowmeter	1 x 5-pin M12 male fixed connector
4 outputs flowmeter	1 x 5-pin M12 male and 1 x 5-pin M12 female fixed connectors

Voltage supply cable

max. 50 m, shielded, 1.5 mm² max. cross-section

Complete device data (sensor fitting S070 + electronic module SE36)

Pipe diameter	DN15...DN100
Measuring range	2...1200 l/min (0.26...320 gpm) for viscosity > 5 mPa.s 3...616 l/min (0.78...320 gpm) for viscosity < 5 mPa.s
Medium temperature with body in aluminium / in stainless steel	0...+80°C (+32...+176°F) / 0...+100°C (+32...+212°F)
Fluid pressure max. DN15 DN25 DN40, DN50 / DN80 / DN100	55 bar (798 PSI) (threaded process connection) 55 bar (798 PSI) ¹⁾ 18 bar (261 PSI) / 12 bar (174 PSI) / 10 bar (145 PSI)
Viscosity	1 Pa.s max. (higher on request)
Measurement deviation	±0.5% of Reading
Programming mode	Threshold, window or hysteresis
Repeatability	≤ 0.03% of Reading



Electrical data

Operating voltage 2 or 3 outputs flowmeter (2-wire) 4 outputs flowmeter (3-wire)	14...36 V DC, filtered and regulated 12...36 V DC, filtered and regulated
Characteristics of the power source (not provided) of UL recognized devices	Limited power source (according to § 9.3 of the UL61010-1 standard) or, Class 2 type power source (according to the 1310/1585 and 60950-1 standards)
Current consumption with sensor 2 or 3 outputs flowmeter (2-wire) 4 outputs flowmeter (3-wire)	≤ 1 A (with transistor loads) ≤ 25 mA (at 14 V DC without transistors load, with current loop) ≤ 5 mA (at 12 V DC without transistors load, without current loop)
Power consumption	40 W max.
Reversed polarity of DC	Protected
Voltage peak	Protected
Short circuit	Protected for transistor outputs
Output Transistor 1 Transistor output (Flowmeter 2-wire) 2 Transistor outputs (Flowmeter 2 or 3-wire) Current 1 Current output (Flowmeter 2-wire) 2 Current outputs (Flowmeter 3-wire)	NPN, open collector, 1...36 V DC, max. 700 mA Configurable as sourcing or sinking (respectively both as PNP or NPN), open collector, max. 700 mA, 0.5 A max. per transistor if the 2 transistor outputs are wired NPN-output: 1...36 V DC PNP-output: Power supply 4...20 mA configurable as sourcing or sinking (in the same mode as transistors), max. loop impedance: 1100 Ω at 36 V DC; 610 Ω at 24 V DC; 180 Ω at 14 V DC max. loop impedance: 1100 Ω at 36 V DC; 610 Ω at 24 V DC; 100 Ω at 12 V DC

Environment

Ambient temperature	0...+60°C (+32...+140°F) (operating and storage)
Relative humidity	≤ 80%, without condensation

Standards, directives and approvals

Protection class	IP65 and IP67 with M12 cable plug mounted and tightened and cover fully screwed down
Standard and directives 	EN 61000-6-2, EN 61000-6-3 Complying with article 3 of Chap. 3 from 97/23/CE directive.* (without CE mark) EN 60068-2-6 EN 60068-2-27
Approvals (only for SE36) UL-Recognized for US and Canada 	UL61010-1 + CAN/CSA-C22.2 No.61010-1

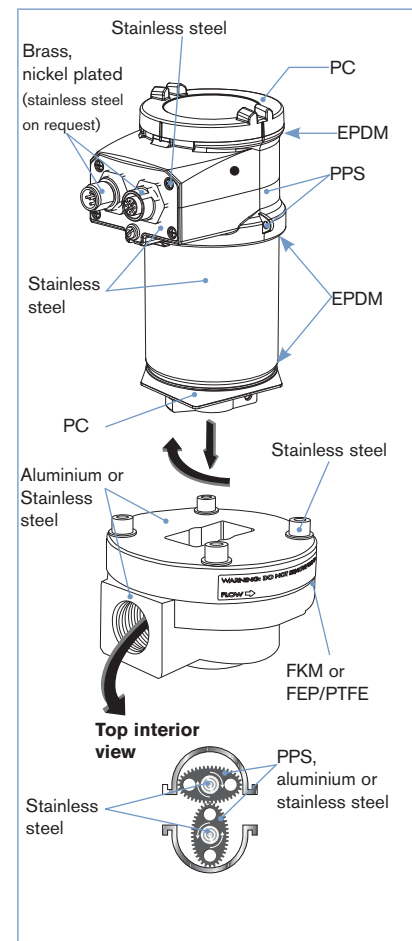
¹⁾ or in accordance to the value of the used flanges**Materials view**

* For the 97/23/CE pressure directive, the device can only be used under following conditions (dependent on max. pressure, pipe diameter and fluid).

Type of fluid	Conditions
Fluid group 1, §1.3.a	Forbidden
Fluid group 2, §1.3.a	DN ≤ 32, or DN > 32 and PN*DN ≤ 1000
Fluid group 1, §1.3.b	PN*DN ≤ 2000
Fluid group 2, §1.3.b	DN ≤ 200

Design and principle of operation

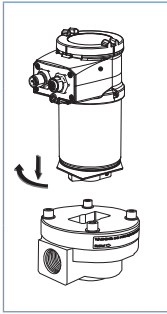

The 8076 flowmeter is built up with an SE36 electronic module associated to a sensor fitting S070 with integrated measurement oval rotor. This connection is made by means of a Quarter-Turn. The output signals are provided via a or two cable glands (according to the flowmeter version).

When liquid flows through the pipe, the rotor turns. This rotation produces a measuring signal in the transducer. The frequency is proportional to the flow of the fluid.

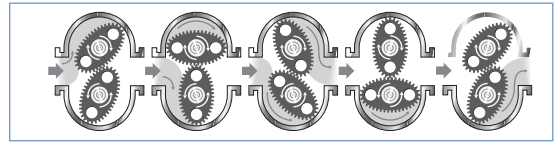

A conversion coefficient (K-factor, available in the instruction manual of the sensor fitting S070), specific to each pipe (size and material) enables the conversion of this frequency into flow rate.

Installation

The sensor fitting can be installed in any orientation as long as **the rotor shafts are always in a horizontal plane** (see figures to the right).

The pipe must be filled with liquid and free from air bubbles. Avoid air purge of the system which would cause damages and to prevent damage from dirt or foreign matter, we strongly recommend the installation of a 250 µm strainer as close as possible to the inlet side of the meter.

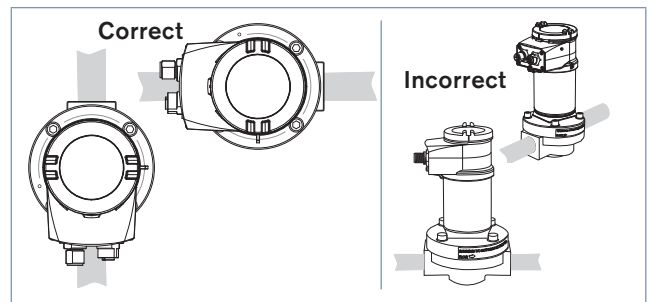

Dimensions [mm]

Electronics SE36

DN	H
15	168
25	182
40	200
50	218
80	258
100	259

DN15	DN25	DN40	DN50	DN80
Threaded connection				
DN25	DN40	DN50	DN80	DN100
Flanged connection				

Ordering information for complete flowmeter Type 8076

A complete flowmeter Type 8076 consists of a ELEMENT electronics Type SE36, a removable display/setting module and a Bürkert INLINE sensor fitting Type S070

The following information is necessary for the selection of a complete device:

- Item no. of the desired electronics **Type SE36** (see ordering chart on p. 5)
- Item no. of the selected INLINE sensor fitting **Type S070** (see separate data sheet- has to be ordered separately)



You have always to order separately two components.

Attention!



When you order devices without display, please take care that you also order at least one display module for the operation.
Order no. of the removable display/setting module (see ordering chart on p. 5)

When you click on the orange box "More info." below, you will come to our website for the resp. product where you can download the data sheet.

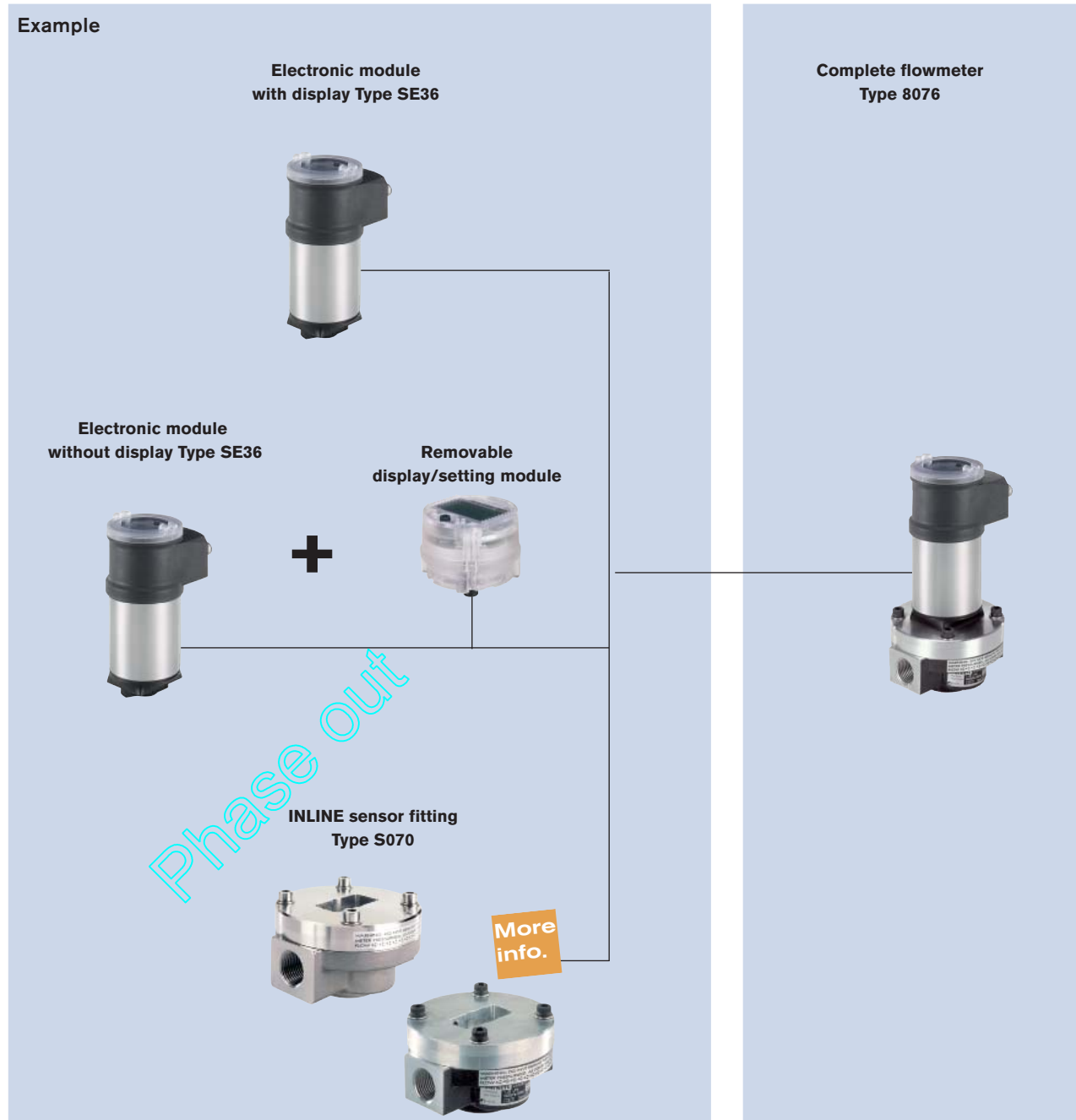
Example







Ordering chart for electronics Type SE36

Specifications	Operating voltage	Output	Electrical connection	UL Approval	Item no.	
					without display	with display
2 outputs	14...36 V DC	1 x transistor + 1 x 4...20 mA (2-wire)	5-pin M12 male fixed connector	No	560 880	561 880
				 Recognized	560 883	561 883
3 outputs	14...36 V DC	2 x transistors + 1 x 4...20 mA (2-wire)	5-pin M12 male fixed connector	No	560 881	561 881
				 Recognized	560 884	561 884
4 outputs	12...36 V DC	2 x transistors + 2 x 4...20 mA (3-wire)	5-pin M12 male and 5-pin M12 female fixed connectors	No	560 882	561 882
				 Recognized	560 885	561 885

Note: Order separately (see accessories)

- M12 cable plugs (only female for single 4...20 mA, 1 male + 1 female for dual 4...20 mA flowmeter)

Ordering chart for accessories (has to be ordered separately)

Description	Item no.
Removable display/setting module (with instruction sheet)	559 168
Blind cover with EPDM seal	560 948
Transparent cover with EPDM seal	561 843
 5 pin M12 female straight cable plug with plastic threaded locking ring, to be wired	917 116
 5 pin M12 male straight cable plug with plastic threaded locking ring, to be wired	560 946
 5 pin M12 female straight cable plug moulded on cable (2 m, shielded)	438 680
 5 pin M12 male straight cable plug moulded on cable (2 m, shielded)	559 177

Interconnection possibilities with other Bürkert products



To find your nearest Bürkert office, click on the orange box →

www.burkert.com

In case of special application conditions, please consult for advice.

Subject to alteration.
© Christian Bürkert GmbH & Co. KG

1604/4_EU-en_00895133