

Manually operated Tank Bottom Valve



- Zero dead volume body - no welds
- Hermetical separation of fluids from the operating mechanism by diaphragm
- Manual Actuator in stainless steel or plastic

Type 3235 can be combined with...



The Bürkert Tank Bottom Valve system is designed for control of ultra pure, sterile, aggressive or abrasive fluids. Enables especially optimal filling and emptying vessels with less dead leg. The valve body consists of a block with no weld seam, machined out of high quality stainless steel. The tank bottom valve has two welding bevels to ease the welding and valve positioning operations. The high quality diaphragms separate hermetically critical fluids from the actuator. The manual actuator in PPS or stainless steel can be sterilized.

Technical data

Orifice	DN 15-100
Body materials	Stainless steel 1.4435BN2 / ASME BPE Fe < 0,5% / C < 0,03%
Diaphragm materials	EPDM (AD), PTFE/EPDM (EA), advanced PTFE/EPDM (EU), Gylon®/EPDM laminated (ER), FKM (FF)
Actuator materials	
Actuator and bonnet	PPS, stainless steel 1.4581
Pilot air ports	Stainless steel 1.4305
Surface finish (others on request)	
inside mechanical polished	Ra ≤ 0,5 µm (ASME BPE SF1) (external Ra ≤ 1.6 µm)
inside electro polished	Ra ≤ 0,38 µm (ASME BPE SF4 / DIN HE4) (external Ra ≤ 1.6 µm)
Medium temperature	
EPDM (AD)	- 10 to + 143 °C (steam sterilisation + 150 °C for 60 min)
PTFE/EPDM (EA)	- 10 to + 130 °C (steam sterilisation + 140 °C for 60 min)
PTFE/EPDM (EU)	- 5 to + 143 °C (steam sterilisation + 150 °C for 60 min)
GYLON®/EPDM laminated (ER)	- 5 to + 130 °C (steam sterilisation + 140 °C for 60 min)
FKM (FF)	0 to + 130 °C (not recommended for steam)
Ambient temperature	+5 to +140 °C
Port connections	
Weld end acc. to	EN ISO 1127 / ISO 4200 DIN 11850 RG2 SMS 3008 ASME BPE BS 4825
Clamp acc. to	ISO 2852 ASME BPE DIN 32676

^{*)}Internal Ra < 0.1 µm/4 µinch/500 Grit: on request

Technical data, continued

Orifice DN diaphragm [mm]	Kv-value water [m³/h]	Max. operating pressure (medium) for seal material EPDM and PTFE/EPDM [bar]
8	1.0	10
15	6.0	10
20	11.0	10
25	16.0	10
40	29.0	10
50	50.0	10 ¹⁾
80	160.0	10
100	235.0	5

¹⁾ Max. operating pressure 7 bar for bonnet and manual actuator in PPS.

Approvals/certifications

Suitability for foodstuffs / sterile applications



- The composition of the EPDM (AD), PTFE/EPDM (EA), advanced PTFE/EPDM (EU) and GYLON®/EPDM laminated (ER) diaphragms corresponds to the Code of Federal Regulations, published by the FDA (Food and Drug Administration, USA).



- The composition of the EPDM (AD), PTFE/EPDM (EA), advanced PTFE/EPDM (EU) and GYLON®/EPDM laminated (ER) diaphragms is suitable for the application with food and beverage (acc. to EC-Regulation 1935/2004/EC)
- The composition of the EPDM (AD), PTFE/EPDM (EA), advanced PTFE/EPDM (EU) and GYLON®/EPDM laminated (ER) diaphragms are approved acc. USP Class VI
- Approval according to TA-air (Port size DN4-50)

Materials

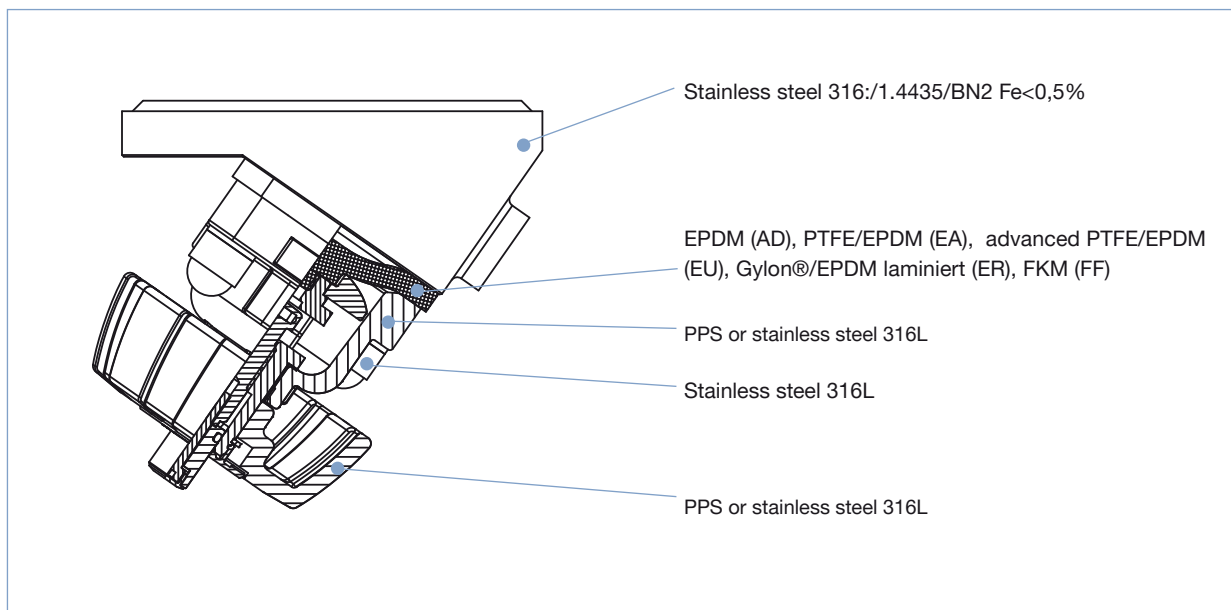

Example of available diaphragm materials

Developed to handle the unique challenges of hygienic and sterile applications, Bürkert offers diaphragms with precise material formula and physical tolerances. Bürkert diaphragms are available in a wide range of materials which have been proven in food & beverage, biotechnology, pharmaceutical and cosmetic industry applications. Bürkert diaphragms are available in a wide range of materials which have been proven in food & beverage, biotechnology, pharmaceutical and cosmetic industry applications. Diaphragms are tested during development and production to ensure reliability in critical processing environments.

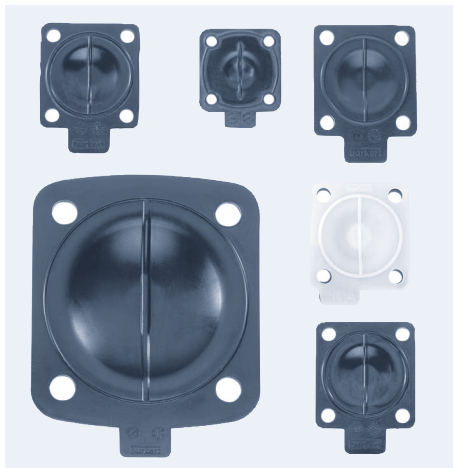

- EPDM (AD)
- PTFE/EPDM (EA)
- advanced PTFE/EPDM (EU)
- FKM (FF)
- Gylon®/EPDM laminated (ER)

Dimensions [mm]

Body with weld end

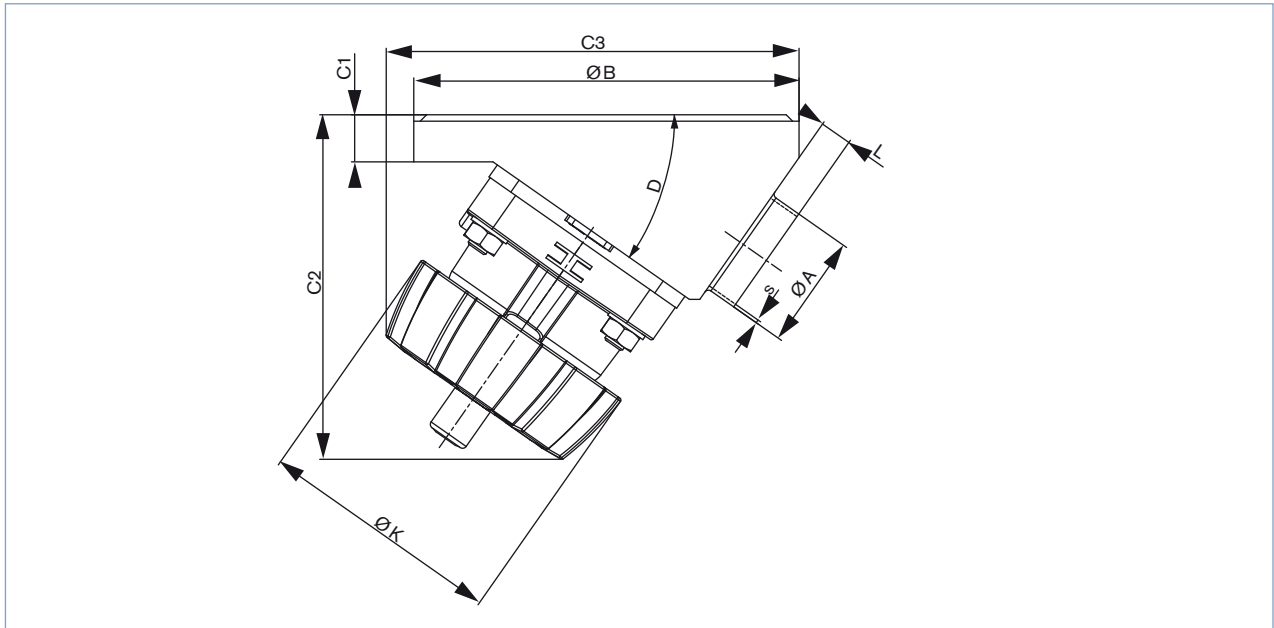

EN ISO 1127 / ISO 4200

Orifice seat [mm]	Port connection [mm]	øA	s	øB	C1	C2	C3	D	øK	L
08	08	13.5	1.6	50	8	65	65	35°	34	5
15	15	21.3	1.6	65	12	103	103	35°	85	3
				85		103	109			8
20	20	26.9	1.6	85	12	109	118	35°	85	5.6
25	25	33.7	2	120	16	117	129	35°	85	8
40	32	42.4	2	150	18	147	180	35°	114	20
	40	48.3	2							15
50	50	60.3	2	180	22	162	194	35°	114	12
80	65	76.1	2	225	20	293	345	40°	223	16
	80	88.9	2.3							10

ASME BPE

Orifice seat [mm]	Port connection [mm]	øA	s	øB	C1	C2	C3	D	øK	L						
08	08	6.35	0.89	50	8	65	65	35°	34	9						
15	15	12.7	1.65	85	12	103	109	35°	85	10						
20	20	19.05	1.65	85	12	109	118	35°	85	8						
25	25	25.4	1.65	120	16	117	129	35°	85	8						
40	40	38.1	1.65	150	18	147	180	35°	114	15						
	50	40	38.1	1.65	180	22	162	194	35°	114	25					
		50	50.8	1.65							15					
80	65	63.5	1.65	225	20	388	422	40°	-	11						
	65	63.5	1.65							225	20	388	422	40°	-	25
	80	76.2	1.65							225	20	293	345	40°	223	16

DIN 11850 RG2

Orifice seat [mm]	Port connection [mm]	øA	s	øB	C1	C2	C3	D	øK	L
08	10	13	1.5	50	8	65	65	35°	34	6
15	15	19	1.5	85	12	103	109	35°	85	8
20	20	23	1.5	85	12	109	118	35°	85	7
25	25	29	1.5	120	16	117	129	35°	85	8
40	40	41	1.5	150	18	147	180	35°	114	20
50	50	53	1.5	180	22	162	194	35°	114	15
80	80	85	2.0	225	20	293	345	40°	223	16

Dimensions [mm], continued

Body with Clamp

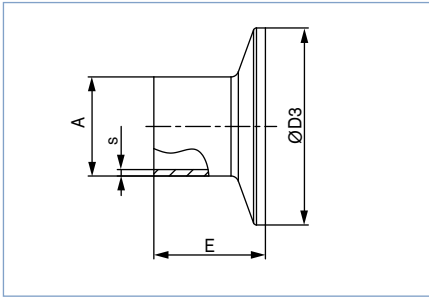

ASME BPE

Orifice [mm]	Orifice [inch]	A	s	D3	E
08	1/4"	6.35	0.89	25.0	28.6
10	3/8"	9.53	0.89	25.0	28.6
15	1/2"	12.7	1.65	25.0	28.6
20	3/4"	19.05	1.65	25.0	28.6
25	1"	25.4	1.65	50.5	28.6
40	1 1/2"	38.1	1.65	50.5	28.6
50	2"	50.8	1.65	64.0	28.6
65	2 1/2"	63.5	1.65	77.5	28.6
80	3"	76.2	1.65	91.0	28.6
100	4"	101.6	2.11	119.0	28.6

DIN 32676

Orifice [mm]	A	s	D3	E
10	1.5	34.0	18	
15	19	1.5	34.0	18
20	23	1.5	34.0	18
25	29	1.5	50.5	21.5
32	35	1.5	50.5	21.5
40	41	1.5	50.5	21.5
50	53	1.5	64.0	21.5
65	70	2.0	91.0	28

ISO 2852 for pipe ISO 4200

Orifice [mm]	A	s	D3	E
8	13.5	1.6	25.0	28.6
8	13.5	1.6	34.0	28.6
10	17.2	1.6	34.0	28.6
15	21.3	1.6	34.0	28.6
15	21.3	1.6	50.5	28.6
20	26.9	1.6	50.5	28.6
25	33.7	2	50.5	28.6
32	42.4	2	50.5	28.6
40	48.3	2	64.0	28.6
50	60.3	2	77.5	28.6
65	76.1	2	91.0	28.6
100	114.3	2.3	130.0	28.6

SMS

Orifice [mm]	A	s	D3	E
25	25	1.2	50.5	21.5
40	38	1.2	50.5	28.6
50	51	1.2	64.0	28.6

Valve features

Example

15 AD B VI F085 SA42 D050 NO15 + NO14 + NK52 + HA24

Specification key

Please make a choice

DIAPHRAGM SIZE

08
15
20
25
40
50
80
100

SEAL MATERIAL

AD	EPDM
EA	PTFE/EPDM
EU	advanced PTFE/EPDM
ER	Gylon®/EPDM laminiert
FF	FKM

PRODUCTION OF BODY

B	Monoblock
---	-----------

BODY MATERIAL

VH	1.4435/AISI 316L
Standard VI	1.4435BN2/ASME BPE

FLANGE

F050	DN08 (Ø 50 mm)
F085	DN15 (Ø 85 mm)
F085	DN20 (Ø 85 mm)
F120	DN25 (Ø 120 mm)
F150	DN40 (Ø 150 mm)
F180	DN50 (Ø 180 mm)
F225	DN80 (Ø 225 mm)
F300	DN100 (Ø 300 mm)

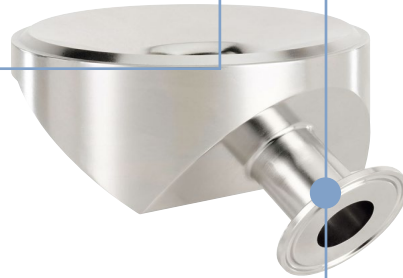

VARIABLE CODES

Surface finish external		
-	clamped Ra ≤ 1.6 µm	stand-ard
NO19	mechanical polished Ra ≤ 1.6 µm	
NO02	mechanical polished Ra ≤ 0.76 µm	
NO28	electro polished Ra ≤ 1.6 µm	
NO15	electro polished Ra ≤ 0.76 µm	

Surface finish, internal		
NO14	mechanical polished Ra ≤ 0.5 µm (ASME BPE SF1)	stand-ard
NO06	mechanical polished Ra ≤ 0.76 µm (ASME BPE SF3 / DIN H2)	
NO17	electro polished Ra ≤ 0.38 µm (ASME BPE SF4 / DIN HE4)	stand-ard
NO16	electro polished Ra ≤ 0.6 µm (ASME BPE SF6)	

Certificate	
NK52	3.1 Certificate

Specific angle	
AF71	45° outlet angle

ACTUATOR VERSION	
D050	Top PPS, handwheel PPS
D058	Top stainless steel, Handwheel PPS for tank bottom
D085	Grey cast iron, white epoxy painted

Orifice	DIN EN ISO 1127 ISO 4200 DIN 11866 series B	SMS 3008	DIN 11850 series 0	DIN 11850 series 1 DIN EN 10357 series B	DIN 11850 series 2 DIN 11866 series A DIN EN 10357 series A	DIN 11850 series 3	BS 4825	ASME BPE DIN 11866 series C
DN 4			SC40 - 6.0x1.0					
DN 6	1/8"	SA78 - 10.2x1.6	SC41 - 8.0x1.0					SA89 - 3.17x0.56
DN 8	1/4"	SA40 - 13.5x1.6	SC42 - 10.0x1.0				SODB - 6.35x1.2	SA90 - 6.35x0.89
DN 10	3/8"	SA41 - 17.2x1.6		SF40 - 12.0x1.0	SD40 - 13.0x1.5	SE40 - 14.0x2.0	SODC - 9.53x1.2	SA91 - 9.53x0.89
DN 15	1/2"	SA42 - 21.3x1.6	SC43 - 18.0x1.5	SF41 - 18.0x1.0	SD42 - 19.0x1.5	SE42 - 20.0x2.0	SODD - 12.7x1.2	SA92 - 12.7x1.65
DN 20	3/4"	SA43 - 26.9x1.6	SC44 - 22.0x1.5	SF42 - 22.0x1.0	SD43 - 23.0x1.5	SE43 - 24.0x2.0	SODE - 19.05x1.2	SA93 - 19.05x1.65
DN 25	1"	SA44 - 33.7x2.0	SA60 - 25.0x1.2	SC45 - 28.0x1.5	SF43 - 28.0x1.0	SD44 - 29.0x1.5	SE44 - 30.0x2.0	SODF - 25.4x1.65
DN 32	1 1/4"	SA45 - 42.4x2.0	SA61 - 33.7x1.2	SC46 - 34.0x1.5	SF44 - 34.0x1.0	SD45 - 35.0x1.5	SE45 - 36.0x2.0	
DN 40	1 1/2"	SA46 - 48.3x2.0	SA62 - 38.0x1.2	SC47 - 40.0x1.5	SF45 - 40.0x1.0	SD46 - 41.0x1.5	SE46 - 42.0x2.0	SODH - 38.1x1.65
DN 50	2"	SA47 - 60.3x2.0	SA63 - 51.0x1.2	SC48 - 52.0x1.5	SF46 - 52.0x1.0	SD47 - 53.0x1.5	SE47 - 54.0x2.0	SODI - 50.8x1.65
DN 65	2 1/2"	SA48 - 76.1x2.0	SA64 - 63.5x1.6			SD48 - 70.0x2.0	SODJ - 63.5x1.65	SODJ - 63.5x1.65
DN 80	3"	SA49 - 88.9x2.3	SA65 - 76.1x1.6			SD49 - 85.0x2.0	SODK - 76.2x1.65	SODK - 76.2x1.65
DN 100	4"	SA39 - 114.3x2.3	SA66 - 101.6x2.0			SD50 - 104.0x2.0	SODL - 101.6x2.11	SODL - 101.6x2.11

Orifice	Clamp 34.0 similar DIN 32676 series B (ISO-tube)	DIN 32676 Reihe A (DIN-Rohr)	DIN 32676 Reihe B (ISO-Rohr)	ASME BPE	BS 4825 Clamp BS 4825-3 Rohr BS 4825-1
DN 8	1/4"	TC51 - 13.5x1.6 Ci: 34.0	TD40 - 10.0x1.0 Ci: 25.0	TC40 - 13.5x1.6 Ci: 25.0	TG50 - 6.35x0.89 Ci: 25.0
DN 10	3/8"	TC41 - 17.2x1.6 Ci: 34.0	TD41 - 13.0x1.5 Ci: 34.0	TC53 - 17.2x1.6 Ci: 25.0	TG01 - 9.53x0.89 Ci: 25.0
DN 15	1/2"	TC42 - 21.3x1.6 Ci: 34.0	TD42 - 19.0x1.5 Ci: 34.0	TC52 - 21.3x1.6 Ci: 50.5	TG02 - 12.7x1.65 Ci: 25.0
DN 20	3/4"		TD43 - 23.0x1.5 Ci: 34.0	TC43 - 26.9x1.6 Ci: 50.5	TG03 - 19.05x1.65 Ci: 25.0
DN 25	1"		TD44 - 29.0x1.5 Ci: 50.5	TC44 - 33.7x2.0 Ci: 50.5	TG04 - 25.4x1.65 Ci: 50.5
DN 40	1 1/2"		TD46 - 41.0x1.5 Ci: 50.5	TC46 - 48.3x2.0 Ci: 64.0	TG05 - 38.1x1.65 Ci: 50.5
DN 50	2"		TD47 - 53.0x1.5 Ci: 64.0	TC47 - 60.3x2.0 Ci: 77.5	TG06 - 50.8x1.65 Ci: 64.0
DN 65	2 1/2"		TD48 - 70.0x2.0 Ci: 91.0	TC48 - 76.1x2.0 Ci: 91.0	TG07 - 63.5x1.65 Ci: 77.5
DN 80	3"			TC49 - 88.9x2.3 Ci: 106.0	TG08 - 76.2x1.65 Ci: 91.0
DN 100	4"			TC50 - 114.3x2.3 Ci: 130.0	TG09 - 101.6x2.11 Ci: 119.0

In case of special application conditions, please consult for advice.

Subject to alteration.
© Christian Bürkert GmbH & Co. KG

1801/10_EU-en_00891855