



## Digital electropneumatic Process Controller

- Compact metal housing
- Graphic display with backlight
- Easy start-up of process controller and positioner
- Comprehensive range of additional software functions
- Profibus DPV1 (optional)
- Assembly acc. to IEC 534-6 / VDI VDE 3845

Type 8793 can be combined with...



**Yoke type actuators**



**Rack/pinion actuators**



**Process control valve with remote Process Controller**

The robust and compact process controller is designed to standardisation acc. to IEC 534-6 or VDI/VDE 3845 for assembly with linear and rotary actuators. In addition, the remote version can be combined with Bürkert process control valves. The digital electropneumatic SideControl process controller can be operated by the usual current and voltage standard signals and can also be equipped with the fieldbus interface PROFIBUS DPV1. Additional to the digital display the valve opening is signaled by a mechanical indicator element. The actual process value is directly supplied to the device as 4-20 mA, PT100 or as frequency signal. The process controller calculates the position setpoint for the subordinated positioner through the variance comparison. Due to the analogue feedback all analogue values on the controlling level can be transferred. The parameterization of process controller and positioner can be carried out automatically.

The easy handling and the selection of additional software functions are done either on a graphic display with backlight and keypad or via PC interface. Operation occurs via external operation and display module consisting of a backlit graphical display and a robust transparency keyboard with for keys with software driven function indication. For the user operation is very simple and clear, identical to the Bürkert positioner or process controller TopControl, type 8692/8693.

The pilot valve system can be used equally for single and double acting actuators. It is characterised by a defined safety feature in case of failure of the electrical or power supply and possesses an enormous air capacity range with pressure supply up to 7 bar.

Technical data	
<b>Material:</b> Body Seal	Aluminium plastic-coated EPDM, NBR, FKM
<b>Operating voltages</b>	24 VDC +/- 10%
<b>Residual ripple</b>	max. 10%
<b>Setpoint setting</b>	0/4 to 20mA and 0 to 5/10 V
<b>Input resistance</b>	0/4 to 20 mA: 180 Ω 0 to 5/10 V: 19 k Ω
<b>Input data for actual value signal</b> Setting 4 - 20 mA Frequency setting  Setting Pt 100	180 Ω Input resistance / Resolution 12 bit 17 kΩ Input resistance, 0 - 1000 Hz / 1‰ o.R.. measuring range, Input signal > 300 mV88 Signal form Sine, rectangle, triangle Measuring range -20 - +220 °C, Resolution < 0.1 °C, M
<b>Analogue feedback</b>	4-20 mA, 0-20 mA 0-10 V, 0-5 V
<b>Binary input</b>	galvanically isolated, 0-5 V = log "0", 10-30 V = log "1"
<b>Binary Output Current limit</b>	2 Outputs (optional), galvanically isolated 100 mA, Output will be synchronised when overloaded
<b>Control medium</b> Dust concentration Particle density Pressure condensation point Oil concentration	Neutral gases, air DIN ISO 8573-1 Class 5 (<40µm particle size) Class 5 (<10mg/m³) Class 3 (<-20°C) Class 5 (<25mg/m³)
<b>Ambient temperature</b>	0 to +60° C
<b>Pilot air ports</b>	Threaded port G 1/4
<b>Supply pressure</b>	1.4 to 7 bar <sup>1)</sup>
<b>Air input filter</b>	Exchangeable (aperture size ~0.1mm)
<b>Pilot valve system</b> Air capacity	Single and double-acting up to 150 l <sub>N</sub> /min. 95 l <sub>N</sub> /min (with 1.4 bar <sup>2)</sup> ) for aeration and ventilation 150 l <sub>N</sub> /min (with 6 bar <sup>2)</sup> ) for aeration and ventilation (QNn = 100 lN/min (acc. to the definition with decrease in pressure from 7 to 6 bar absolute)
<b>Position detection module</b>	Potentiometer, max. angle 180°

*continued on next page*

<sup>1)</sup> The supply pressure has to be 0.5-1 bar above the minimum required pilot pressure for the valve actuator  
<sup>2)</sup> Pressure specifications: Overpressure with respect to atmospheric pressure

Technical data, continued





Technical data	
Stroke range valve spindle	Min. 30° on the rotary shaft, independent of lever
Installation	As required, display above or sideways
Type of protection	IP 65/67 acc. to EN 60529 (NEMA4x in preparation)
Power consumption	< 5 W
Electrical connection	
Multi-pin connection	M12, 8-pin / 4-pin; M8, 4-pin
Cable gland	2xM20x1.5 (cable-Ø10mm) on screw terminals (0.14-1.5 mm <sup>2</sup> )
Remote Version	1xM12x1.5 (cable Ø3 to 6,5mm)
Bus communication	Profibus DPV1 (optional)
Inductive proximity switch	on request
Protection class	3 acc. to VDE 0580
Type of ignition protection	II 3 G nA II B T4 (in preparation) II 3 D tD A22 T135° (in preparation)
Conformity	EMV2004/108/EG
Approvals	CSA (in preparation)

Technical data - Position Sensor Remote	
Type of protection	IP 65/67 acc. to EN 60529 (NEMA4x in preparation)
Electrical connection	
Length for connection cable	10m
Cable gland	1xM16x1,5 (cable Ø5-10mm) on terminal screws (0,14-1,5 mm <sup>2</sup> )
Actual signal position	digital (RS485)
Ambient temperature	-25 to +80 V:
Protection class	3 acc. to VDE 0580
Type of ignition protection	II 3 G nA II B T4 (in preparation) II 3 D tD A22 T135° (in preparation)
Conformity	EMV2004/108/EG
Approvals	CSA (in preparation)

Using a remote positioner the length of the control air pipes influences the dynamics and attainable accuracy of the position control loop. The length of the control air pipes therefore should be as short as possible.

Example for assembly variations of Process Controller SideControl

Process Controller SideControl Type 8793

 <b>Linear actuators</b> <b>IEC 534-6</b>	 <b>Rotary actuators</b> <b>VDI/VDE 3845</b>  <b>Type 8805</b> <b>+</b> <b>Type 8793</b>	 <b>Control valve system</b>  <b>Type 2300</b> <b>+</b> <b>Type 8793</b> <b>Remote Process Controller</b> <b>+</b> <b>Type 8798</b> <b>Remote Position Sensor</b>	 <b>Control valve system</b>  <b>Type 2702</b> <b>+</b> <b>Type 8793</b> <b>Remote Process Controller</b> <b>+</b> <b>Type 8798</b> <b>Remote Position Sensor</b>
--	---	--	---

Assembly options

Standard Version

(Positioner with integrated position sensor, assembly acc. to NAMUR/IEC 534-6 and VDI/VDE 3845)

Assembly on rotary actuator



Item no. for adapter kit	787 338
Item no. assembly bridge	770 294

Dimensions [mm]

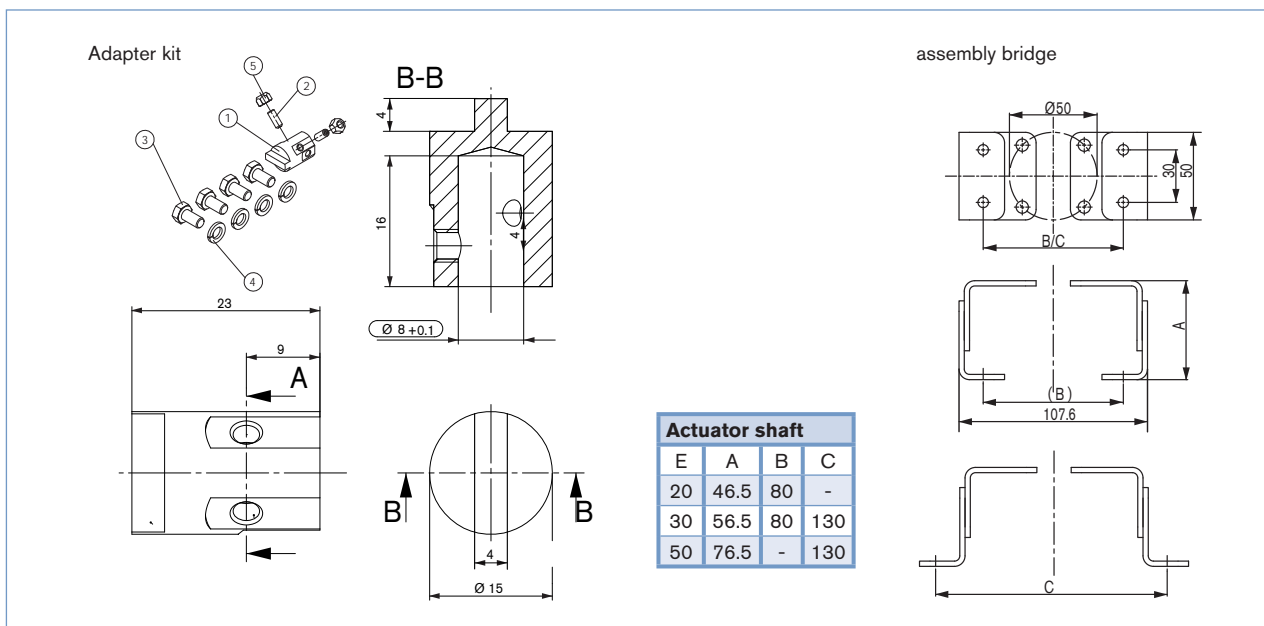

Assembly on linear actuator



Item no. for adapter kit	787 215
--------------------------	---------

Assembly options *continued*

Remote Version

(Positioner remote from actuator with displacement positioner)

Assembly with accessory brackets

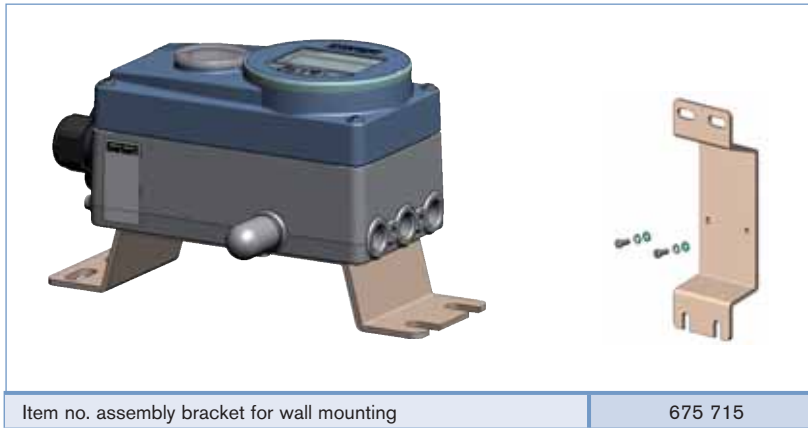

Dimensions [mm]

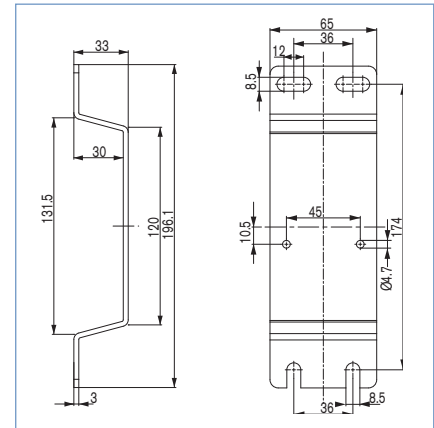

Assembly on DIN-Rail

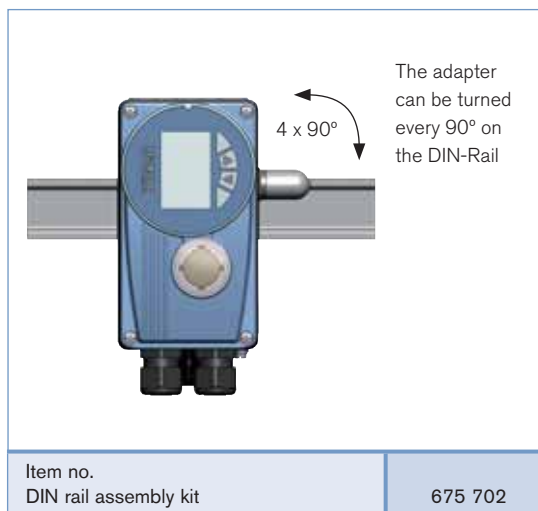

Dimensions [mm]

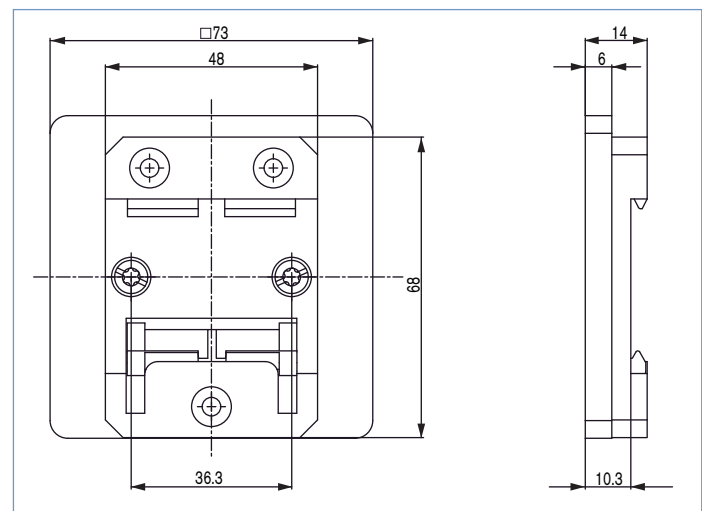

**Assembly options *continued***

**Remote Version**

(Remote positioner from actuator with displacement positioner)

**Type 8798**



Item no.	
Remote Position Sensor	
Control valves CLASSIC Type 27xx	211 535
Control valves ELEMENT Type 23xx	212 360

**Dimensions**

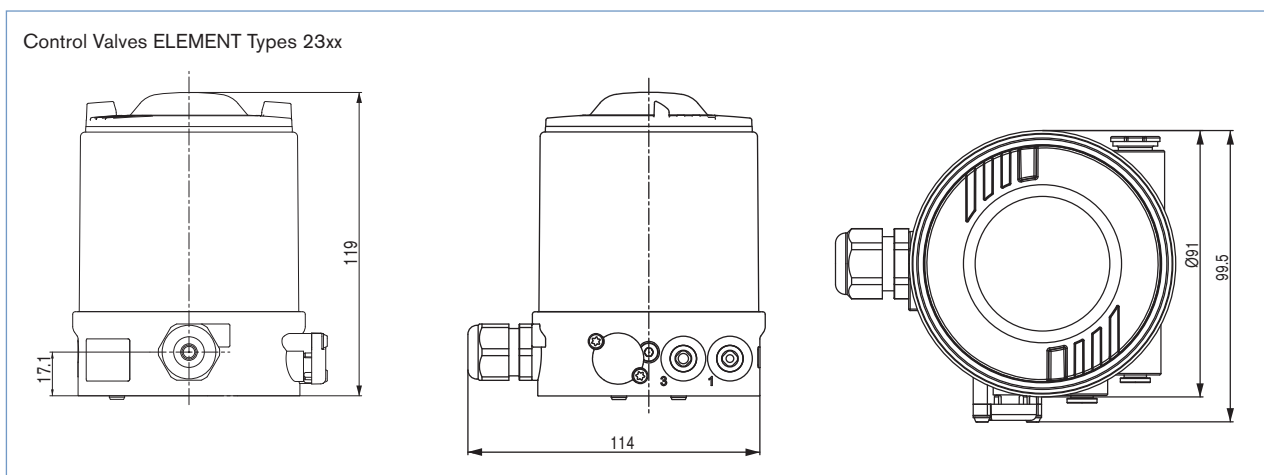
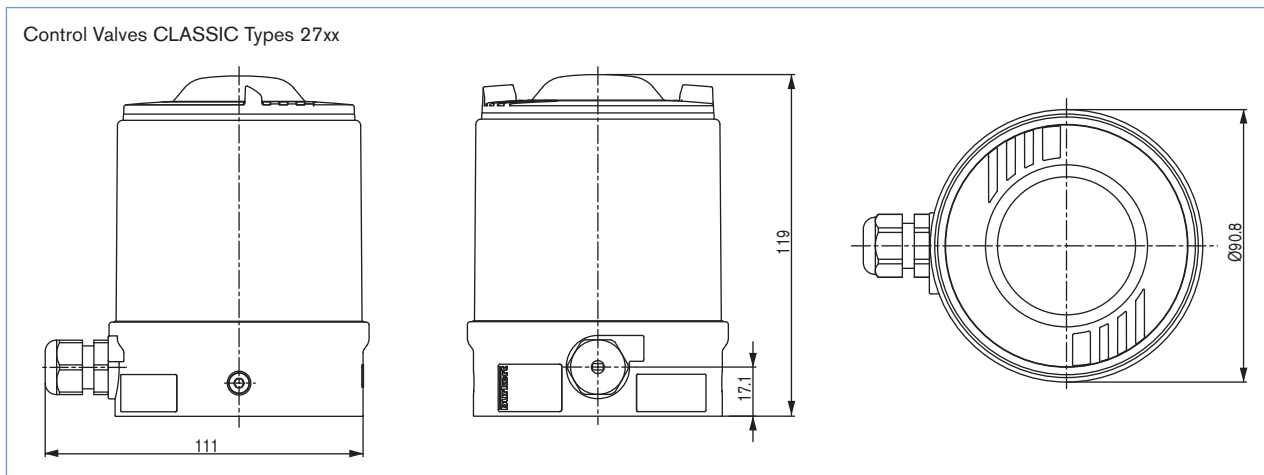

DTS 1000121144 EN Version: D validé) printed: 15.04.2010 Status: RL (released | freigegeben |

Ordering chart (other versions on request)

Assembly variations	Communication	Electrical connection	Analogue feedback	2 Binary outputs	Binary input	Initiator	Control function single and double-acting	Item no.
NAMUR IEC 534-6 VDI/VDE 3845	no	Cable gland	no	no	yes	no	yes	206 593
			no	no	yes	2	yes	on request
			no	yes	yes	no	yes	206 595
			yes	yes	yes	no	yes	206 594
			yes	yes	yes	2	yes	on request
		Multi-pin	no	no	yes	no	yes	206 596
			no	no	yes	2	yes	on request
			no	yes	yes	no	yes	206 599
			yes	yes	yes	no	yes	206 598
	Profibus DPV1	Multi-pin	via Bus	no	yes	no	yes	206 600
			via Bus	no	yes	2	yes	on request
			via Bus	yes	yes	no	yes	206 601
	Remote	no	Cable gland	no	no	yes	no	yes
no				yes	yes	no	yes	206 609
yes				yes	yes	no	yes	206 608

**i Further versions on request**

- > Additional**  
Remote Version (Positioner remote from actuator with displacement positioner sensor)  
II 3 G nA II B T4  
II 3 D tD A22 T135°  
Initiators for end position feedback

Ordering chart for accessories

Description	Item no.
Assembly bridge VDI/VDE 3845, Stainless steel	770 294
Adapter kit VDI/VDE 3845, Stainless steel	787 338
Adapter kit linear actuators IEC 534-6, stainless steel	787 215
Silencer G 1/4" (replacement part)	780 780
M12 socket, 8-pin, 2 m cable set	919 061
M8 plug, 4-pin for binary outputs, without cable	917 131
<b>Accessories for Remote Version</b>	
Bracket for wall mounting, Stainless steel	675 715
Holder for DIN-Rail assembly Al/Stainless steel	675 702
Remote position sensor control valves CLASSIC Type 27xx	211 535
Remote position sensor control valves CLASSIC Type 23xx	212 360
Adapter kit for remote position sensor control valves Type 23xx	665 721
Adapter kit for remote position sensor control valves Type 27xx	
Actuator size Ø80mm	677 214
Actuator size Ø100mm	677 215
Actuator size Ø125mm	677 216
Actuator size Ø175/Ø225mm	677 217

DTS 1000121144 EN Version: D valide) printed: 15.04.2010 Status: RL (released | freigegeben |

Connection options

Multi-pin connection

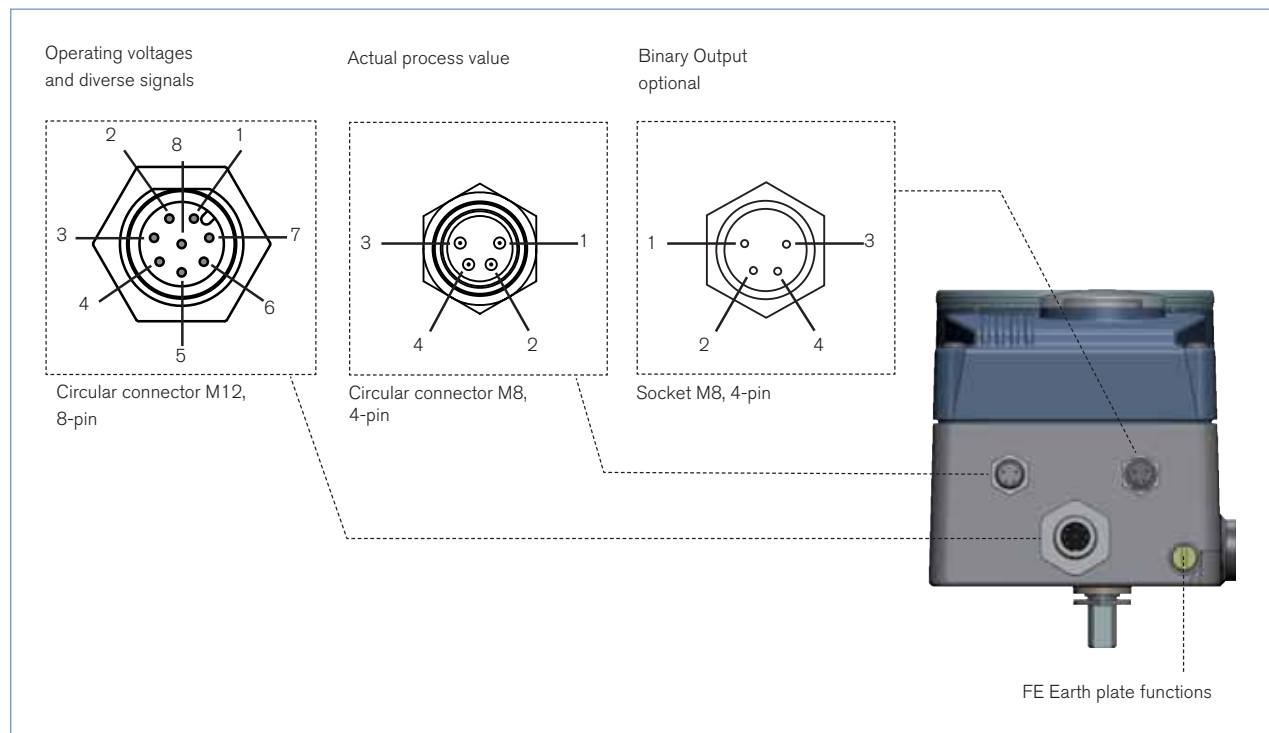

Circular connector M12 - 8-pin (Setpoint)

Pin	Configuration	External Circuitry / level signal
1	Setpoint + (0/4-20 mA or 0-5/10 V)	1  + (0/4-20 mA or 0-5/10 V) Completely galvanically separated
2	Setpoint GND	2  GND
3	GND	3  24 V DC ± 10% max. residual ripple 10%
4	+ 24 V	4
5	Binary input +	5  +  0-5 V (log. 0) 10-30 V (log. 1)
6	Binary Output GND	6  GND

Optional analogue feedback

8	Analogue feedback +	8  + (0/4-20 mA or 0-5/10 V) Completely galvanically separated
7	Analogue feedback GND	7  GND







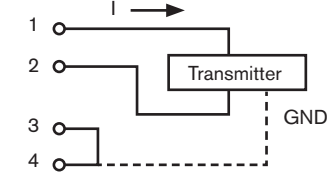

Socket M8, 4-pin (only with optional Binary Output)

Pin	Configuration	External Circuitry / level signal
1	Binary output 1	1  0-24 V
2	Binary output 2	2  0-24 V
3	Binary Output GND	3  GND

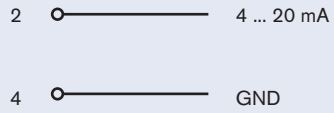
Connection options

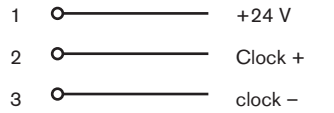
Multi-pin connection, *continued*

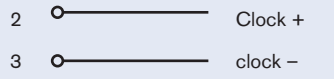
Plug assignments of the process actual value input (M8 circular plug)

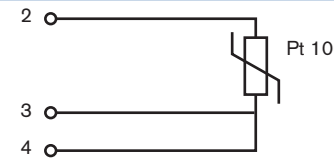
Input type*	Pin	Configuration	DIP switch	External Circuitry
4 ... 20 mA - internally supplied	1 2 3 4	+24 V Transmitter supply Output from transmitter GND Bridge after GND (GND from 3-conductor transmitter)	 Switch on left	
4 ... 20 mA - externally supplied	1 2 3 4	Not used Process actual + Not used Process actual -	 Switch on right	
Frequency - internally supplied	1 2 3 4	+24 V sensor supply Clock input + Clock input - (GND) Not used	 Switch on left	
Frequency - externally supplied	1 2 3 4	Not used Clock input + Clock input - Not used	 Switch on right	
Pt 100 (see note below)	1 2 3 4	Not used Process actual 1 (power supply) Process actual 3 (GND) Process actual 2 (compensation)	 Switch on right	

\*adjustable through Software

Connection options, continued

PROFIBUS-DP connection

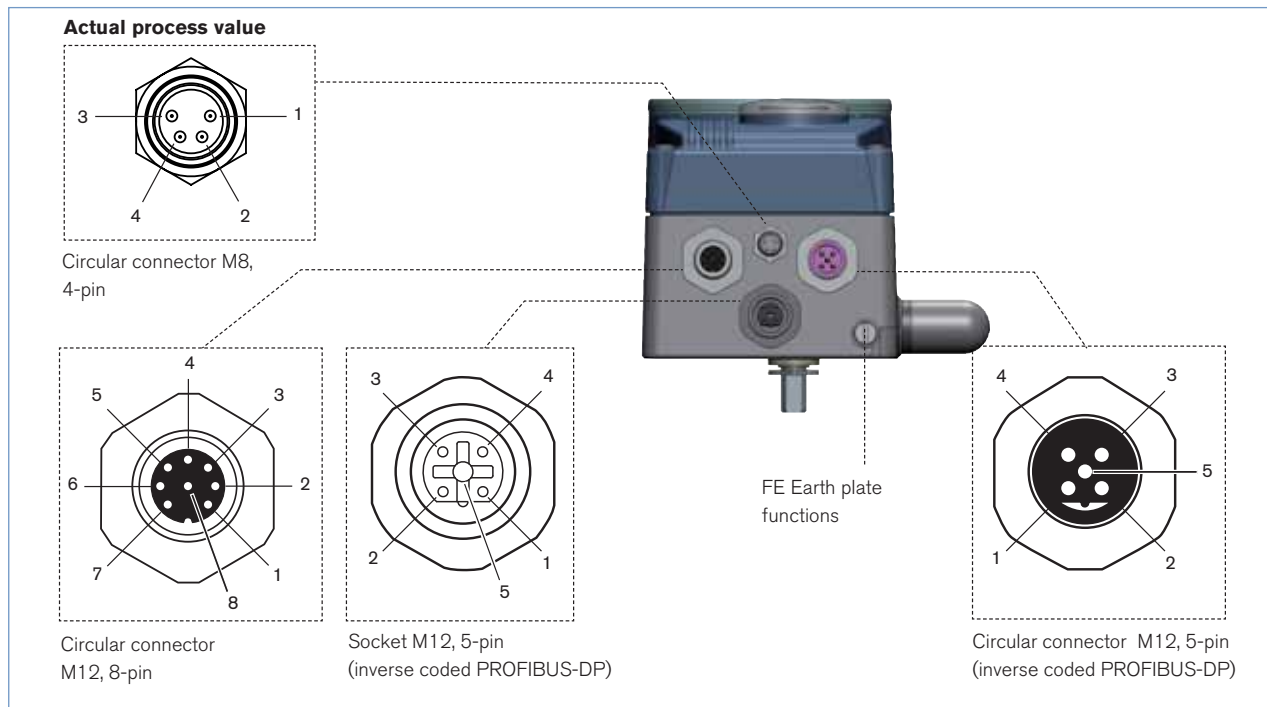

Operating voltages - Circular connector M12, 8-pin

Pin	Configuration	External Circuitry / level signal
1	Not used	
2	Not used	
3	GND	<p>24 V DC ± 10 % max. residual ripple 10 %</p>
4	+24 V	
5	Binary input +	
6	Binary input -	
7	Binary output 1 (oriented at Pin 3)	
8	Binary output 2 (oriented at Pin 3)	

Bus-Connection - socket/Circular connector M12, 5-pin

Pin	Configuration	External Circuitry / level signal
1	VP+5	Load resistance supply
2	RxD/TxD-N	Receive and send information -N, A Circuitry
3	DGND	Information transfer potential (measured to 5 V)
4	RxD/TxD-P	Receive and send information -N, A Circuitry
5	Shield	Shield / protective earth

DTS 1000121144 EN Version: D validé printed: 15.04.2010 Status: RL (released | freigegeben |

Connection options, continued

Cable gland connection

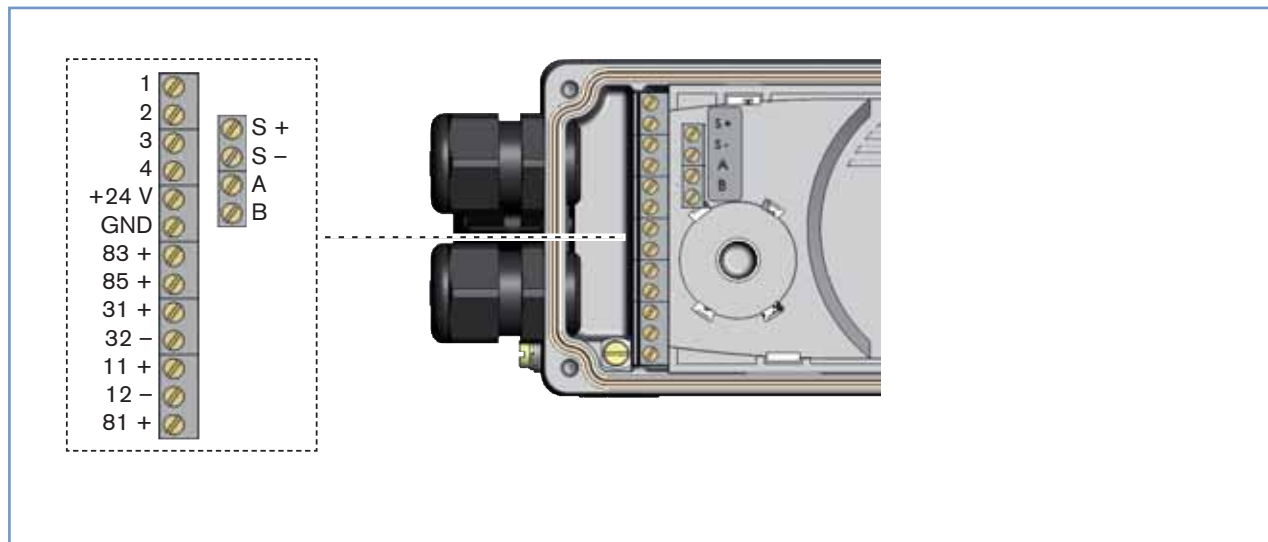

Terminal	Configuration	External Circuitry / level signal
11 +	Setpoint +	11 +  + (0/4 ... 20 mA or 0 ... 5 / 10 V) Complete galvanic separation
12 -	Setpoint GND	12 -  GND
81 +	Binary input +	81 +  +  0 ... 5 V (log. 0) 10 ... 30 V (log. 1) Obtained at GND operating voltages (GND clamps)
+24 V	Operating voltages +	+24 V  24 V DC ± 10 %
GND	Operating voltages GND	GND  Max. residual ripple 10 %

Optional analogue feedback / Binary output

Terminal	Configuration	External Circuitry / level signal
83 +	Binary output 1	83 +  24 V / 0 V, NC / NO obtained at GND operating voltages ( GND clamps)
85 +	Binary output 2	85 +  24 V / 0 V, NC / NO obtained at GND operating voltages ( GND clamps)
31 +	Analogue feedback +	31 +  + (0/4-20 mA or 0-5/10 V) completely galvanically isolated,
32 -	Analogue feedback GND	32 -  GND

Optional remote version in connection with remote position sensor, Type 8798

Terminal	Configuration	External Circuitry
S+	Supply Sensor -	S+
S-	Supply Sensor +	S-
A	Serial interface, B Cicutry	A  A Cicutry
B	Serial interface, A Cicutry	B  B Cicutry

Remoter  
Sensor  
Type 8798

Connection options, continued

Cable gland connection

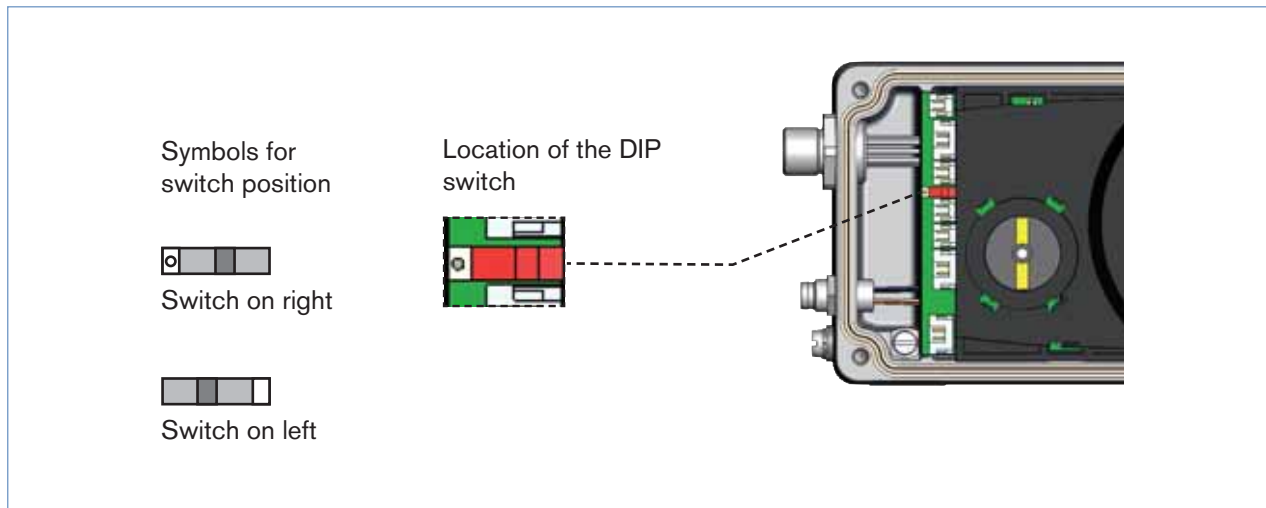

Input type*	Terminal	Configuration	External Circuitry
4 ... 20 mA - internally supplied	Actual process value	1 +24 V transmitter input 2 Output from transmitter 3 Bridge after GND (GND from 3-conductor transmitter) 4 Not used	
	GND	GND	
Frequency - internally supplied	Actual process value	1 +24 V sensor supply 2 Clock input + 3 Not used 4 Clock input -	
	GND	GND	
4 ... 20 mA	Actual process value	1 Not used 2 Process actual + 3 Process actual - 4 Not used	
Frequency - externally supplied	Actual process value	1 Not used 2 Clock input + 3 Not used 4 Clock input -	
Pt 100 (see note below)	Actual process value	1 Not used 2 Process actual 1 (power supply) 3 Process actual 3 (GND) 4 Process actual 2 (compensation)	

\*adjustable through Software

## Signal flow plan

### Process control loop

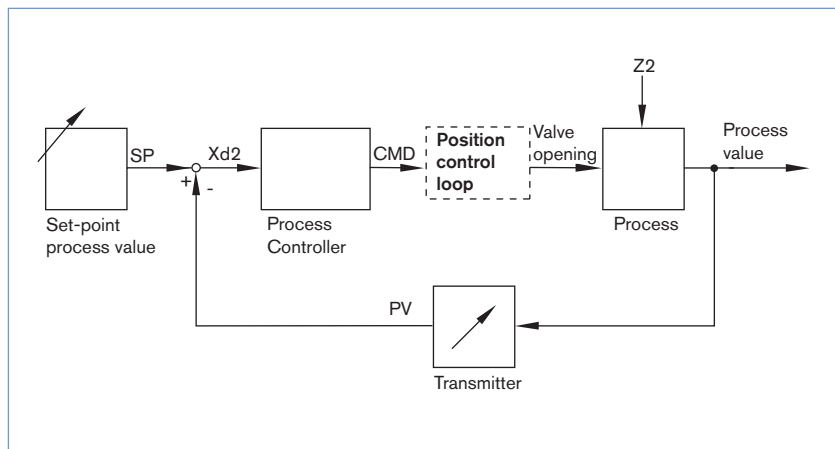

### Additional software options of the process controller SideControl Type 8793 (extract)

- Automatic start of the control system
- Automatic parameterisation of the process control loop
- Automatic or manual characteristics curves selection
- Setting of the seal and the maximum stroke threshold respectively
- Parameterisation of the Positioner
- Manual parameterisation of process controller
- Limitation of the stroke range
- Limitation of the manipulating speed
- Setting of the moving direction
- Configuration of the binary input
- Signal range splitting on several controllers
- Configuration of analogue or 2 binary outputs
- Signal fault detection
- Safety position
- Code protection
- Contrast inversion of the display
- Diagnostic functions

### Position control loop

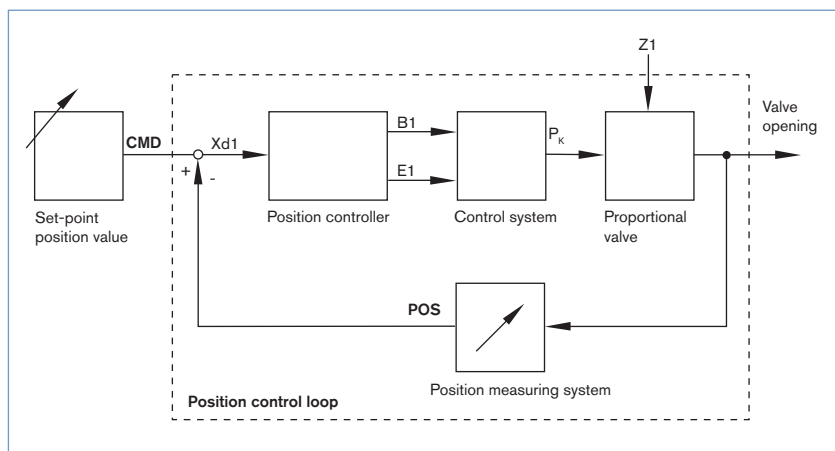

**Schematic diagram of SideControl, Type 8793**

without fieldbus interface

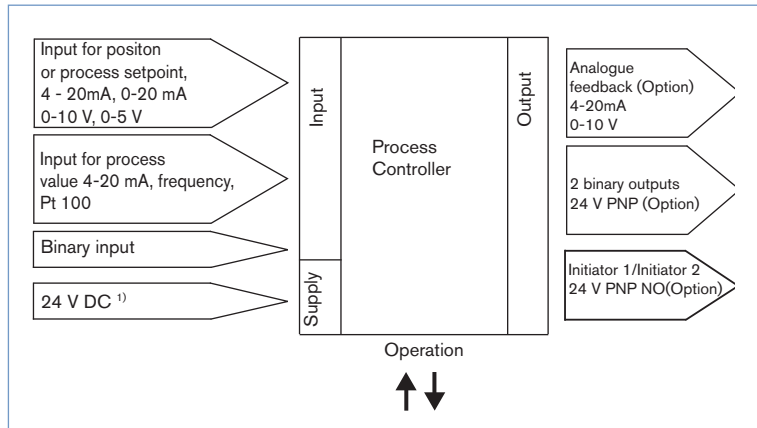

**With Profibus DP**

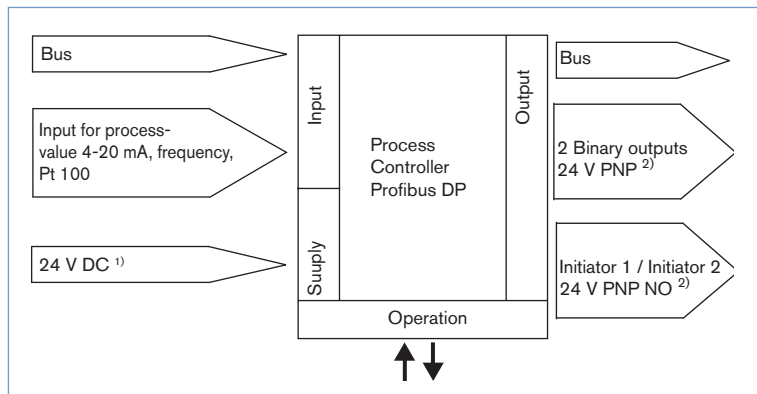

<sup>1)</sup> The operating voltage is supplied with a 3-wire unit independent from the setpoint signal

<sup>2)</sup> Alternative options

Dimensions [mm]

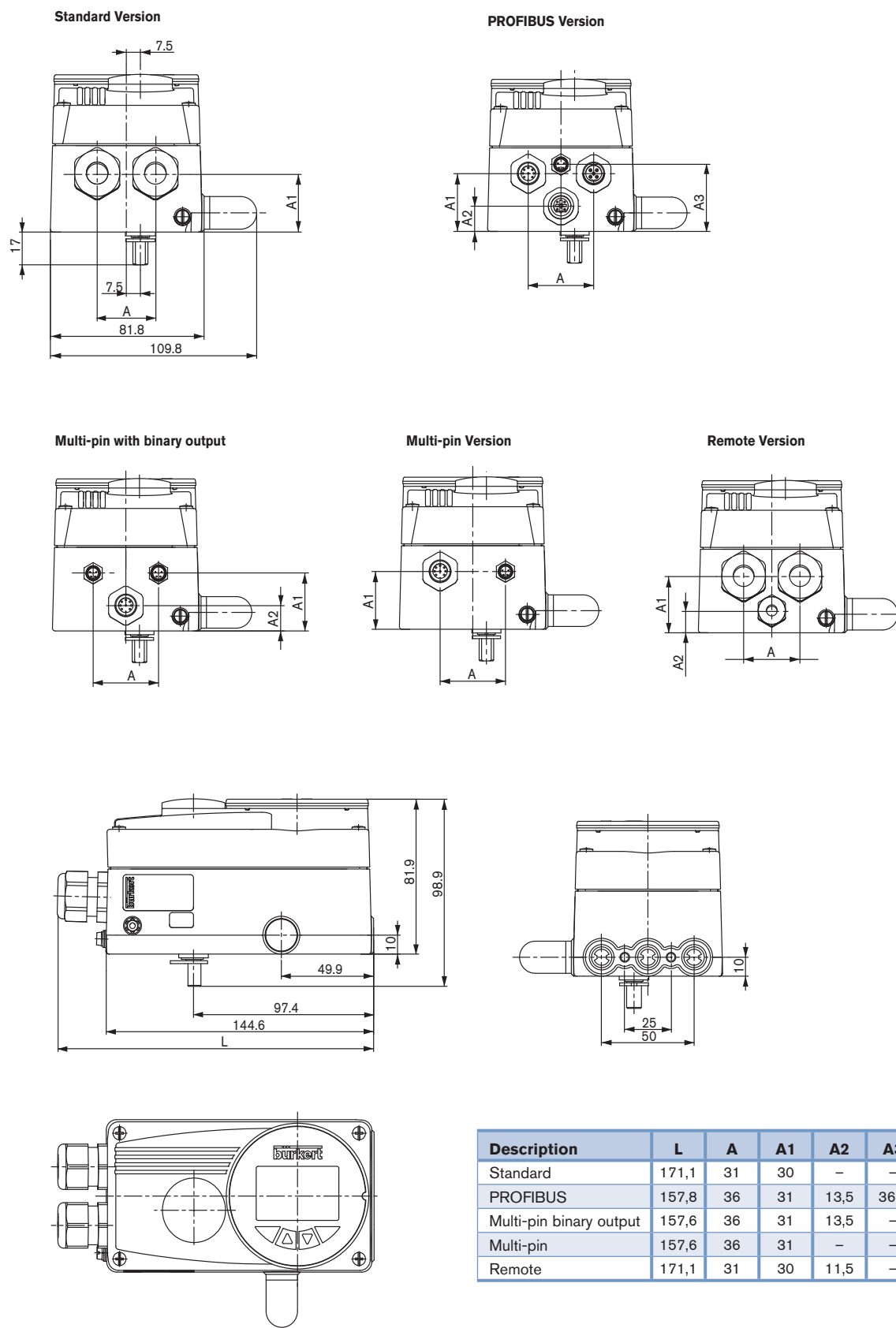

DTS 1000121144 EN Version: D valide) printed: 15.04.2010 Status: RL (released | freigegeben |

Dimensions [mm]

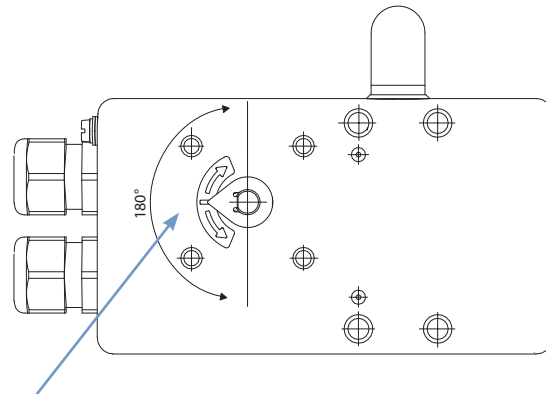

The rotation angle of the sensor must be within a range of 180°

With the valve open approx. 50%, the sensor indicator should be in this position.

Standard Version

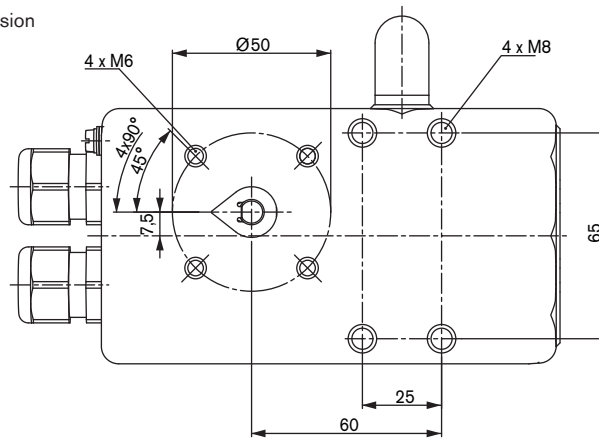

Remote Version

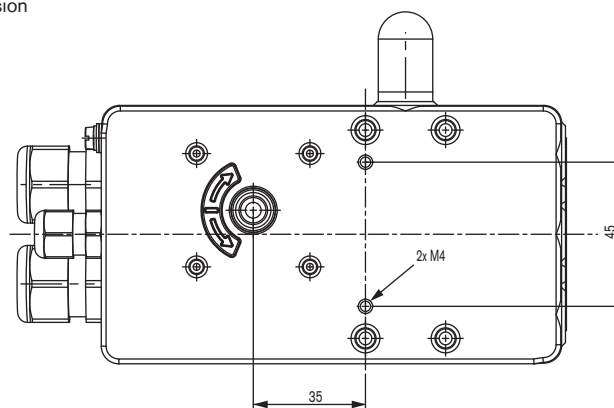

DTS 1000121144 EN Version: D validé printed: 15.04.2010 Status: RL (released | freigegeben |

To find your nearest Bürkert facility, click on the orange box → [www.burkert.com](http://www.burkert.com)

In case of special application conditions,  
please consult for advice

Subject to alterations.  
© Christian Bürkert GmbH & Co. KG

1004/4\_EU-en\_00895120