



Type 8791 BASIC can be combined with...



Yoke type actuators



Rack/pinion actuators



Process control valve with remote positioner

Digital electropneumatic positioner

- Compact metal housing
- Simple start-up using tune function
- Dynamic pilot valve system with higher air capacity
- Comprehensive range of additional software functions using Kommunikations software with parameters
- Assembly acc. to IEC 534-6 / VDI VDE 3845

The robust and compact positioner is designed to a standardisation acc. to IEC 534-6 or VDI/VDE 3845 for assembly with linear and rotary actuators. In addition, the remote version with the displacement position sensor can be combined with Bürkert process control valves

The setpoint setting for the electro-pneumatic digital Positioner SideControl BASIC occurs using a standard signal 4...20mA or with AS-Interface as an option. In addition there is a binary input and an optional analogue feedback available.

The valve opening is signalled by a mechanical indicator element and the device status is shown on three coloured LEDs. All the operational elements are found in the housing.

The start-up happens automatically, and directly at the device the following functions by a DIP switches are activated:

- Close tight function
- Inversion of the operating direction of the setpoint signal
- Characteristic curves selection
- Switching - manual and automatic operation

Additional possibilities on configuration and parameter setting, for example, linearisation of the operation characteristics by using communications software which allows customised programming

The pilot valve system can be used equally for single and double-acting drives. It is characterised by a defined safety feature in case of failure of the electrical or pneumatic power supply and possesses an enormous air capacity range with pressure supply up to 7 bar.

Technical data	
Material	
Body	Aluminium plastic-coated
Seal	EPDM, NBR, FKM
Operating voltages	24 VDC +/- 10%
Residual ripple	max. 10%
Setpoint setting	4-20mA (0-20mA adjustable using configurations software)
Input resistance	0/4 to 20 mA: 180 Ω
Analogue feedback	4-20 mA, 0-20 mA (optional) (max. Burden 560Ω)
Binary input	0-5 V = log "0", 10-30 V = log "1"
Control medium	Neutral gases, air DIN ISO 8573-1
Dust concentration	Class 5 (<40µm particle size)
Particle density	Class 5 (<10mg/m ³)
Pressure condensation point	Class 3 (<-20°C)
Oil concentration	Class 5 (<25mg/m ³)
Ambient temperature	0 to +60°C
Pilot air ports	Threaded ports G 1/4
Supply pressure	1.4 bis 7 bar ¹⁾
air supply filter	Exchangeable (mesh aperture~0.1mm)
Actuator system	
Air capacity	Single and double-acting up to 150 l _N /min. 95 l _N /min (with 1.4 bar ²⁾) for aeration and ventilation 150 l _N /min (with 6 bar ²⁾) for aeration and ventilation (Q _{Nn} = 100 l _N /min (acc. to the definition with decrease in pressure from 7 to bar absolute)
Position detection module	Potentiometer max. angle 180°
Stroke range valve spindle	Min. 30° on the rotary shaft, depending on lever
Installation	As required, display above or sideways
Type of protection	IP 65/67 acc. to EN 60529 (NEMA4x in preparation)
Power consumption	< 3.5 W

continued on next page

¹⁾ The supply pressure has to be 0.5-1 bar above the minimum required pilot pressure for the valve actuator

²⁾ Pressure values [bar]: Overpressure with respect to atmospheric pressure

Technical data, continued

Technical data	
Electrical connection	
Multipole connection	M12, 8-pin
Cable gland	2xM20x1.5 (cable-Ø10mm) on screw terminals (0.14-1.5 mm ²)
Remote Version	1xM12x1.5 (cable Ø3 to 6.5 mm)
Bus communication	AS-Interface (in preparation)
Inductive proximity switches	(in preparation)
Protection class	3 acc. to VDE 0580
Type of ignition protection	II 3 G nA II B T4 (in preparation) II 3 D tD A22 T135° (in preparation)
Conformity	EMV2004/108/EG
Approvals	CSA (in preparation)

Technical data - Remote Position Sensor	
Type of protection	IP 65/67 acc. to EN 60529 (NEMA4x in preparation)
Electrical connection	
Cable length for connection cable	10m
Cable gland	1xM16x1.5 (cable-Ø5-10mm) on Terminal screws (0.14-1.5 mm ²)
Signal Istoposition	digital (RS485)
Ambient temperature	-25 to +80 °C
Protection class	3 acc. to VDE 0580
Type of ignition protection	II 3 G nA II B T4 (in preparation) II 3 D tD A22 T135° (in preparation)
Conformity	EMV2004/108/EG
Approvals	CSA (in preparation)

Using a remote positioner the length of the control air pipes influences the dynamics and attainable accuracy of the position control loop. The length of the control air pipes therefore should be as short as possible.

Example of assembly variations of Positioner SideControl

Positioner SideControl Type 8791 BASIC



**Linear actuators
IEC 534-6**

**Rack/pinion
actuators
VDI/VDE 3845**

**Control valve
system**

**Control valve
system**

Type 8805
+
Type 8791
BASIC

Type 2300
+
Type 8791
BASIC
Remote
+
Type 8798
Remote
Position Sensor

Type 2702
+
Type 8791
BASIC
Remote
+
Type 8798
Remote
Position Sensor

Assembly options

Standard Version

(Positioner with integrated position sensor, assembly acc. to NAMUR/IEC 534-6 and VDI/VDE 3845)

Assembly on rotary actuator



Item no. for adapter kit	787 338
Item no. assembly bridge	770 294

Dimensions [mm]

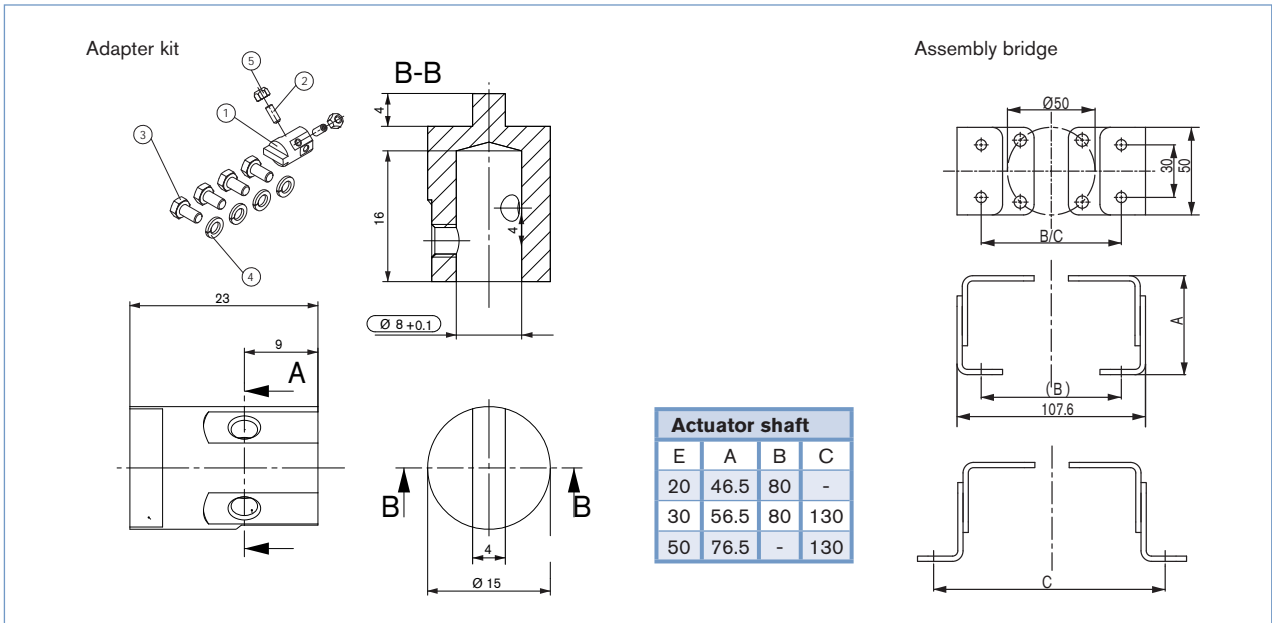

Assembly on linear actuator



Item no. for adapter kit	787 215
---------------------------------	---------

Assembly options *continued*

Remote version

(Remote positioner from actuator with displacement position)

Assembly with accessory brackets

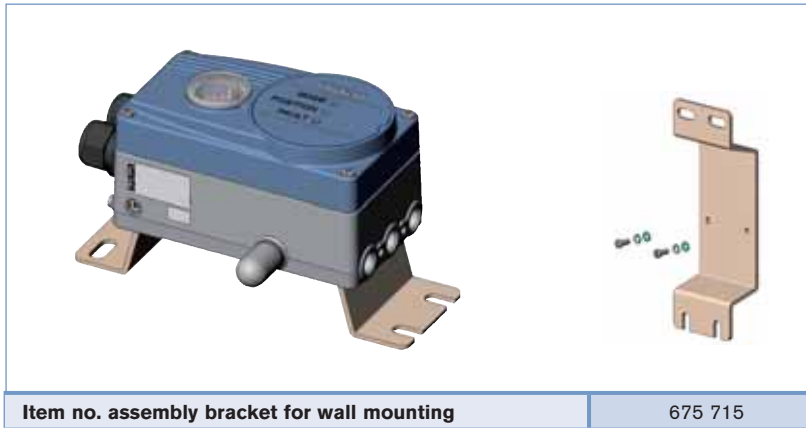

Dimensions [mm]

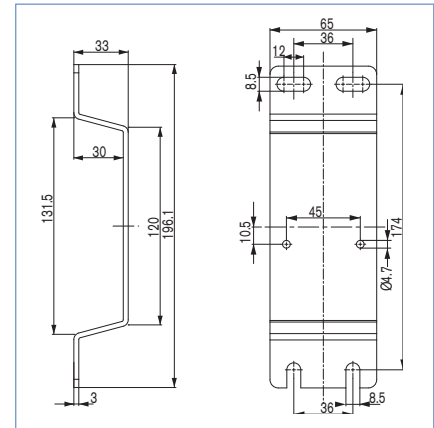

Assembly on DIN-Rail



Dimensions [mm]

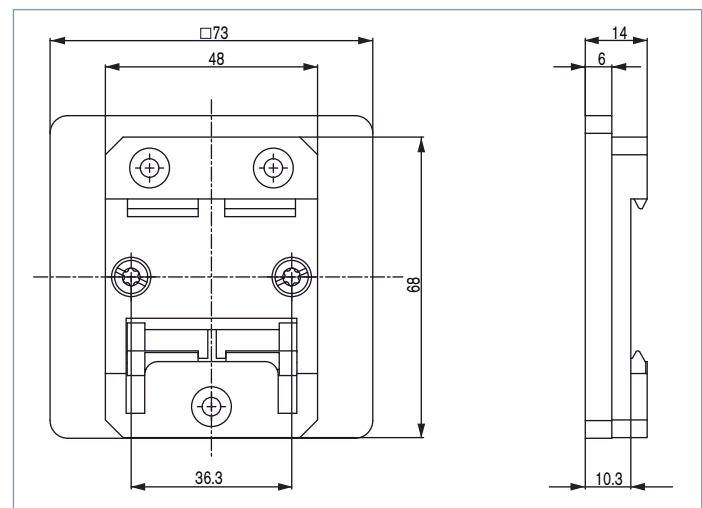

Assembly options *continued*

Remote version

(Remote positioner from actuator with displacement position sensor)

Type 8798



Item no.

Remote Position Sensor

Control valves CLASSIC Types 27xx	211 535
Control valves ELEMENT Types 23xx	212 360

Dimensions

Control valves CLASSIC Types 27xx

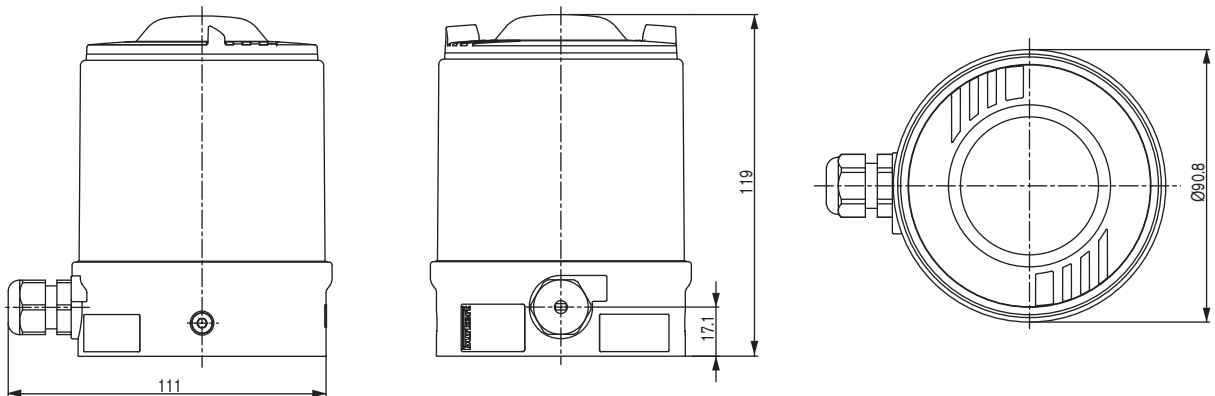

Control valve ELEMENT Types 23xx

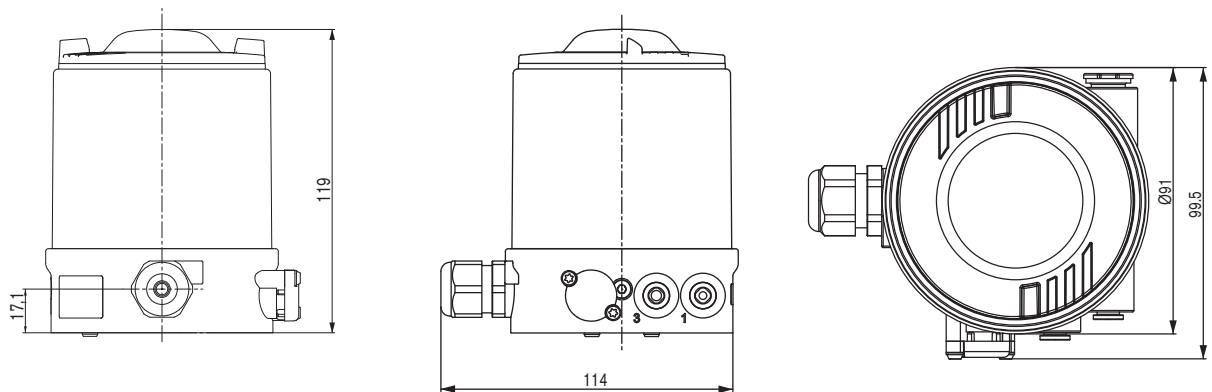

Ordering chart (other versions on request)

Assembly variations	Communication	Electrical connection	Analogue feedback	Binary input	Initiator	Control function single and double-acting	Item no.
NAMUR IEC 534-6 VDI/VDE 3845	no	Cable gland	no	yes	no	yes	211 521
			yes	yes	no	yes	211 522
		Multiple	no	yes	no	yes	211 523
			yes	yes	no	yes	211 524
Remote	no	Cable gland	no	yes	no	yes	211 531
			yes	yes	no	yes	211 532

i Further versions on request

> **Additional**
inductive proximity switches
AS-Interface Communication

🔍 **Approval**
II 3 G nA II B T4
II 3 D tD A22 T135°
Type of protection NEMA 4x
CSA-Approval

Ordering chart for accessories

Description	Item no.
Assembly bridge VDI/VDE 3845, Stainless steel	770 294
Adapter kit VDI/VDE 3845, Stainless steel	787 338
Adapter kit linear actuators IEC 534-6, stainless steel	787 215
Silencer G 1/4" (replacement part)	780 780
M12 socket, 8-pin, 2 m cable set	919 061
PC-interface configuration / Parameter tool RS232*	659 467
Accessories Remote version	
Bracket for wall mounting, Stainless steel	675 715
DIN rail assembly kit	675 702
Remote sensor control valves CLASSIC Types 27xx	211 535
Remote sensor control valves ELEMENT Types 23xx	212 360
Adapter kit remote sensor ELEMENT Types 23xx	665 721
Adapter kit remote sensor CLASSIC Types 27xx	
Actuator size Ø 80mm	677 214
Actuator size Ø 100mm	677 215
Actuator size Ø 125mm	677 216
Actuator size Ø 175/ Ø225mm	677 217

*: Associated communications software for Type 8791 can be downloaded at www.burkert.com

Connection options

Cable gland connection

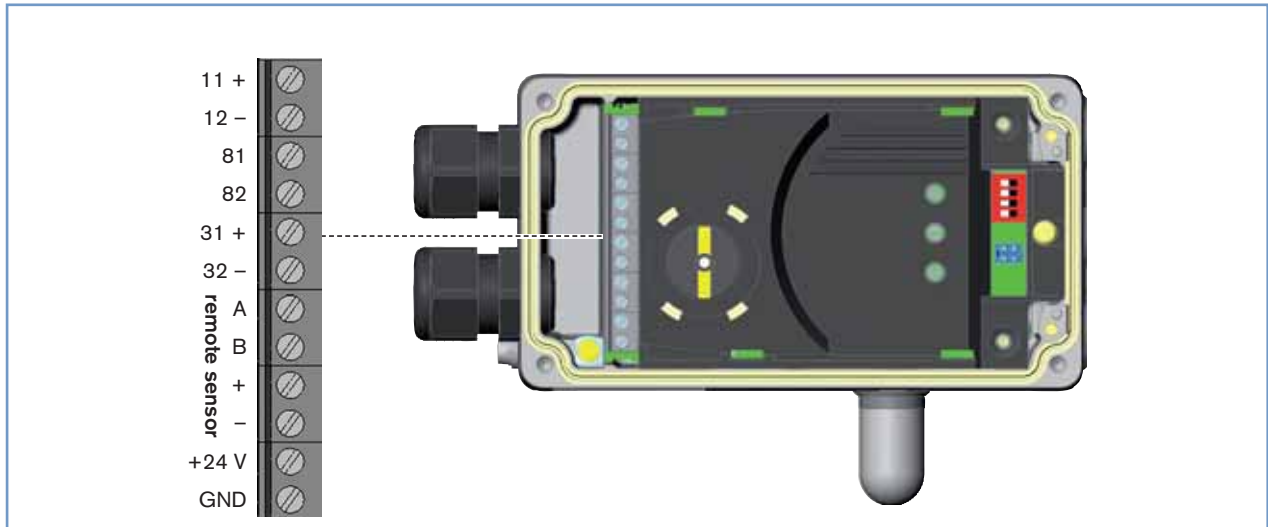

Input signal

Terminal	Configuration	External Circuitry / level signal
11 +	Setpoint +	11 + + (0/4 ... 20 mA) not galvanically isolated
12 -	Setpoint GND	12 - GND
81 +	Binary input +	81 + + 0 ... 5 V (log. 0) 10 ... 30 V (log. 1)
82 -	Binary input -	82 - GND
+24 V	Operating voltages +	+24 V 24 V DC ± 10 % max. residual ripple 10 %
GND	Operating voltages GND	GND

Output signal with optional analogue position feedback

Terminal	Configuration	External Circuitry / level signal
31 +	Analogue feedback +	31 + + (0/4 ... 20 mA) not galvanically isolated
32 -	Analogue feedback GND	32 - GND

Optional remote version in connection with remote positioner sensor Type 8798

Terminal	Configuration	External Circuitry / level signal
S +	Supply sensor +	S + +
S -	Supply sensor -	S - -
A	Serial Interface, A cable	A A line
B	Serial Interface, B cable	B B line

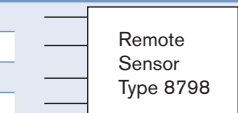

Remote sensor Type 8798

Terminal	Wire colour for cable type		Configuration	External Circuitry
	1	2		
1	white	black	Supply Sensor -	1 8791 or
2	brown		Supply Sensor +	2 8792 / 8793
3	yellow	orange	Serial Interface, B line	3 8791 or
4	green	red	Serial Interface, A line	4 8792 / 8793

Connection options, *continued*

Multi-pin connection

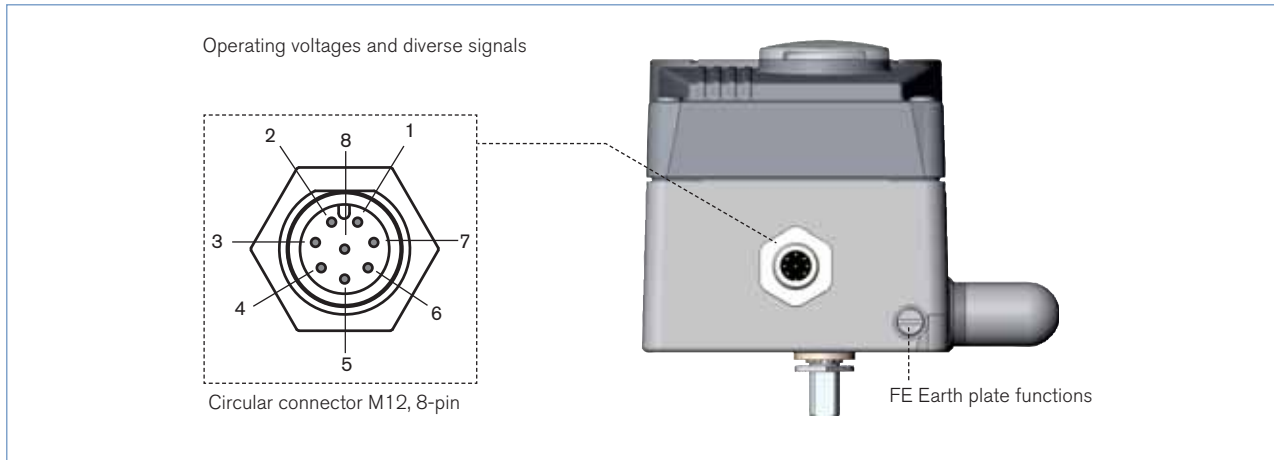

Circular connector M12 - 8-pin (Input signal)

Pin	Wire colours*	Configuration	External Circuitry / level signal
1	white	Setpoint + (0/4-20 mA)	1 + (0/4 -20 mA) not galvanically isolated
2	brown	Setpoint GND	2 GND
5	grey	Binary Output	5 + 0-5 V (log. 0) 10-30 V (log. 1) obtained on Pin 3 (GND)
3	green	GND	3
4	yellow	+ 24 V	4 24 V DC ± 10% max. Residual ripple 10%

Circular connector M12 - 8-pin (Output signal with optional analogue position feedback)

8	red	Analogue feedback +	8 + (0/4 -20 mA) not galvanically isolated
7	blue	Analogue feedback GND	7 GND

* The indicated wire colours refer to the connection cable, part no. 919061, available as an accessory

Signal flow plan

Position control loop

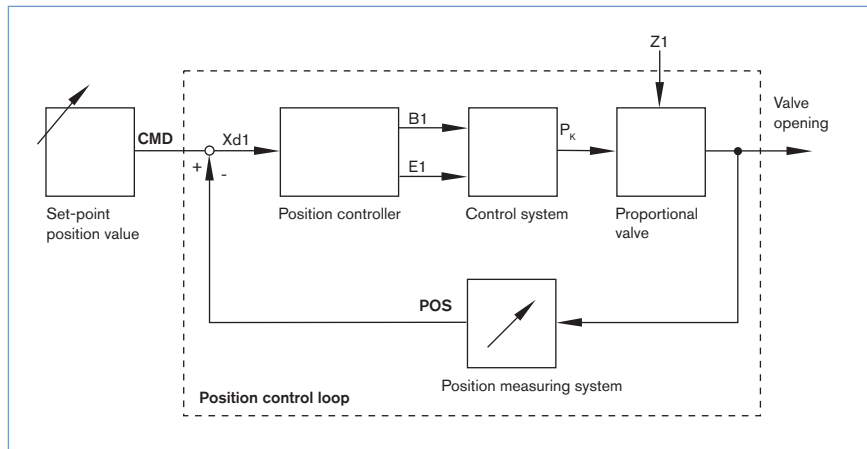

SideControl BASIC functions

- Automatic start of the control system
- Binary input (safety position)
- Analogue position feedback (optional)

DIP-Switch activated device

- Close tight function
- Inversion of the operating direction of the setpoint signal
- Linear characteristic curves selection or customised programming (software interface)
- Manual and automatic operation

Communications software with activatable and parameter driven functions

- Customised programming transmission characteristics
- Choices of setpoint signal
- Range splitting setpoint signal
- Limitation of the valve stroke
- Limitation of the operation speed
- Definition of the safety position
- Signal failure detection

Schematic diagram of SideControl Type 8791 BASIC

without fieldbus interface

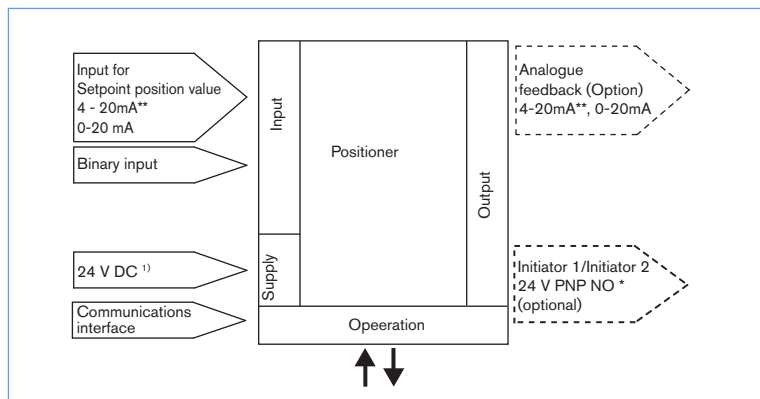

* in preparation
**Default setting

Dimensions [mm]

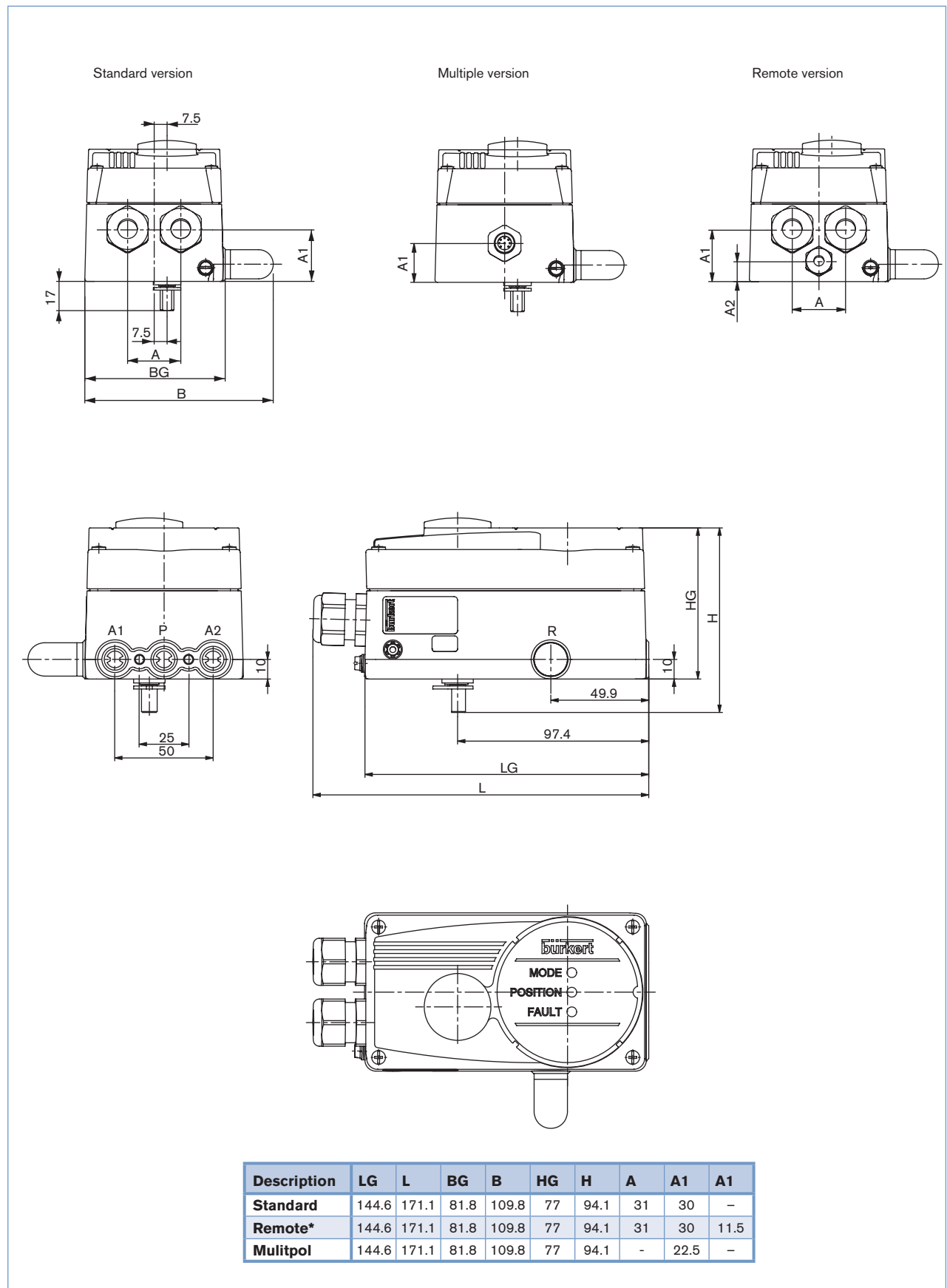

Dimensions [mm], continued

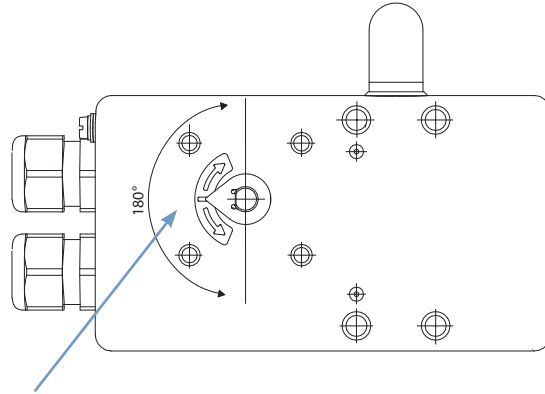

The rotation angle of the sensor must be within a range of 180°

With the valve open approx. 50%, the sensor indicator should be in this position.

Standard Version

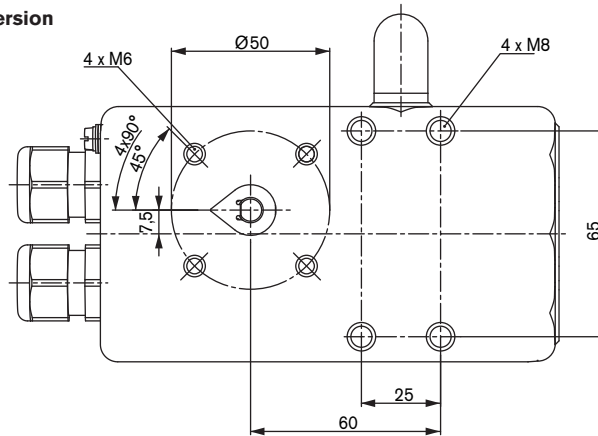

Remote version

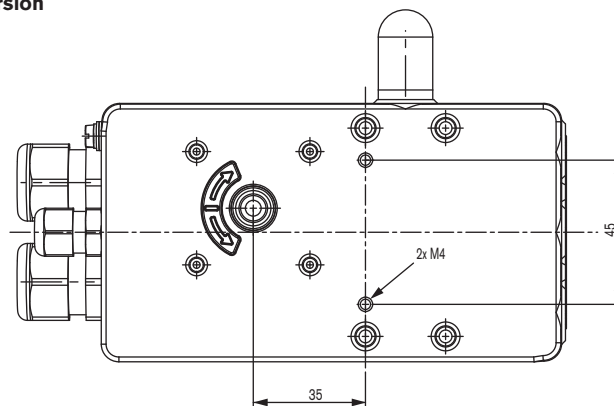

DTS 1000123308 EN Version: B Status: RL (released | freigegeben | validé) printed: 13.05.2010

To find your nearest Bürkert facility, click on the orange box → www.burkert.com

In case of special application conditions,
please consult for advice

Subject to alterations.
© Christian Bürkert GmbH & Co. KG

1004/2_EU-en_00895131