

Digital batch controller



Type 8035B can be combined with...



Type S030
INLINE fitting



Type 6213
Solenoid valve



Type 2712 (8630)
Continuous
TopControl system

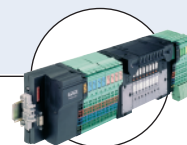

Type 8644
Valve islands

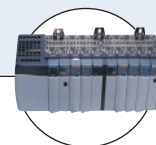

PLC

- Compact version for DN06 to DN65
- Dosing
- Automatic calibration: Teach-In
- Possible check of input/output signals
- Batched volume and totalizers displayed

The batch controller is especially designed for use in neutral, slightly aggressive, solid free liquids. The batch controller is made up of a compact fitting with paddle-wheel (S030) and an electronic module (SE35) quickly and easily connected together by a Quarter-Turn.

The Bürkert designed fitting system ensures simple installation of the sensors into all pipes from DN06 to DN65.

Technical data	
General data	
Compatibility	with fittings S030 (see corresponding data sheet)
Materials	Housing, cover, lid, nut Front panel foil / Screws Cable plug or glands Wetted parts materials Fitting, sensor armature Paddle-wheel Axis and bearing / Seal
Display	15x60 mm, 8-digit LCD, alphanumeric, 15 segments, 9 mm high
Electrical connections	Cable glands M20x1.5
Voltage supply cable	max. 50 m, shielded, 1.5 mm ² max. cross-section
Complete device data (Fitting S030 + Electronics)	
Pipe diameter	DN06 to DN65
Measuring range	0.3 to 10 m/s (Hall transducer version)
Fluid temperature with fitting in PVC / PP PVDF, brass or stainless steel	0°C up to 50°C (32°F to 122°F) / 0°C up to 80°C (32°F to 176°F) -15°C up to 100°C (5°F to 212°F)
Fluid pressure max.	PN10 (145.1 PSI) (with plastic fitting) - PN16 (232.16 PSI) (with metal fitting) - (PN40 on request, see S030 data sheet) - see Pressure/Temperature diagram
Viscosity / Pollution	300 cSt. max. / 1% max (size: max. 0.5 mm)
Accuracy Teach-In Standard K-factor	±0.5% of F.S.* (at 10 m/s) ¹⁾ ±(0.5% of F.S.* + 2.5% of Reading) ¹⁾
Linearity	±0.5% of F.S.* (at 10 m/s) ¹⁾
Repeatability	≤ 0.4% of Reading ¹⁾

¹⁾ Under reference conditions i.e. measuring fluid=water, ambient and water temperature=20°C (68°F), applying the minimum inlet and outlet pipe straights, matched inside pipe dimensions.
* F.S.=Full scale (10 m/s)

8035 Batch Controller INLINE



Electrical data	
Power supply (V+)	12-30 V DC \pm 10%, filtered and regulated or 115/230 V AC 50/60 Hz (see technical specifications 115/230 V AC)
Reversed polarity of DC	protected
Current consumption with sensor (without consumption of inputs/outputs)	\leq 70 mA
Input	4 binary inputs, 5... 30 V DC - impedance 3.3 k Ω Functions: dosing quantity choice, start-stop dosing
Output	Polarized, potential free, 5...30 V DC; 100 mA, protected, line drop at 100 mA: 1.5 V DC - for status and alarm messages Relay 2 relays, freely configurable, 3 A, 230 V AC
Environment	
Ambient temperature	0°C up to +60°C (operation and storage)
Relative humidity	\leq 80 %, without condensation
Standards, directives and approvals	
Protection class	IP65 with cable or screws plug mounted and tightened or with obturator locked if not used.
Standard and directives	EN 61000-6-3 (2001), EN 61000-6-2 (2001) EN 61010-1 Complying with article 3 of chap. 3 from 2006/95/CE directive.* EN 60068-2-6 EN 60068-2-27
EMC Security Pressure (Fitting S030, DN06 to DN65, in PVC, PP, PVDF, stainless steel or brass) Vibration Shock	
Technical specifications 115/230 V AC	
Voltage supply available inside the device	27 V DC regulated - max. current: 125 mA integrated protection: fuse 125 mA temporised power: 3 VA

Accuracy diagram

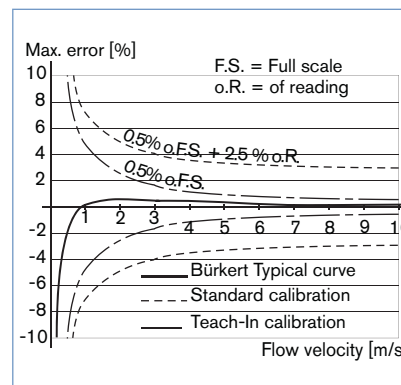

* For the 2006/95/CE pressure directive, the device can only be used under following conditions (depend on max. pressure, pipe diameter and fluid).

Type of fluid	Conditions
Fluid group 1, chap. 1.3.a	DN \leq 25 only
Fluid group 2, chap. 1.3.a	DN \leq 32, or DN > 32 and PN*DN \leq 1000
Fluid group 1, chap. 1.3.b	PN*DN \leq 2000
Fluid group 2, chap. 1.3.b	DN \leq 200

Operation and display

The device can be calibrated by means of the K-factor, or via the Teach-In function. User adjustments, such as measuring range, engineering units, pulse output and filter are carried out on site. The operation is specified according to three levels:

► Indication in operating mode/Display

- dosing amount
- dosing mode
- main totalizer
- daily totalizer with reset function

► Parameter definition

- language
- engineering units
- K-factor/Teach-In function
- selection of batching mode
- over run correction
- alarm
- function mode of relays
- reset main totalizer

► Test

- display of state of binary inputs
- relay test
- frequency test of sensor



Design and principle of operation



The electronic housing of the 8035 integrates the electronic board with display, setting parameter keys and also a transducer (Hall). The paddle-wheel is mounted in the fitting. The output signals are provided via two cable glands. Bürkert designed fitting (S030) ensures simple installation of the Bürkert transmitter into pipes from DN06 to DN65.

When liquid flows through the pipe, the 4 magnets, inserted in the paddle-wheel set in rotation, produce a measuring signal in the transducer. The frequency modulated induced voltage is proportional to the flow velocity of the fluid. A conversion coefficient (K factor, available in the S030 instruction manual of the fitting), specific to each pipe (size and material) enables the conversion of this frequency into volume. The electronic component converts the measured signal and displays the actual volume.

The 8035 batch controller is mounted in a pipe in series with the valve; the unit controls the opening of the valve and measures the quantity of the fluid which flows. The unit also closes the valve when the pre-programmed quantity has been delivered.

The electronic component needs a voltage supply of 12-30 V DC or 115/230 V AC, and two output relays are used to activate the valves and to initiate alarms.

The following dosing and filling operations are possible:

- **Local dosing:** the user enters the quantity to be metered and initiates the dosage from the keypad.
- **Local dosing with pre-set quantity:** the user selects a quantity which has been preset and initiates the dosage from the keypad.
- **Remote control dosing** using a rotary knob (selecting a pre-set quantity) or binary data inputs.
- **Dosing controlled by a PLC unit** using binary data inputs.
- **Automatic dosing controlled by variation of pulse duration.** The quantity of the dose is directly proportional to the duration of a pulse.

Installation

The SE35 electronic can easily be installed into any Bürkert INLINE fitting system (S030) by means of a Quarter-Turn.

Minimum straight upstream and downstream distances must be observed. According to the pipe's design, necessary distances can be bigger or use a flow conditioner to obtain the best accuracy. For more information, please refer to EN ISO 5167-1.

EN ISO 5167-1 specifies the straight inlet and outlet distances that must be complied with when installing fittings in pipelines in order to achieve calm flow conditions. The most important layouts that could lead to turbulence in the flow are shown below, together with the associated minimum inlet and outlet distances. These ensure calm, problem-free measurement conditions at the measurement point.

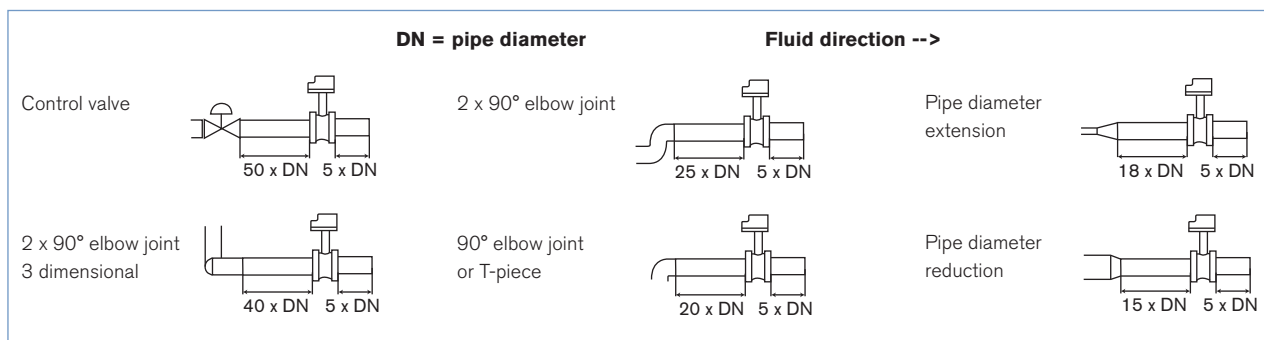

The batch controller can be installed into either horizontal or vertical pipes.

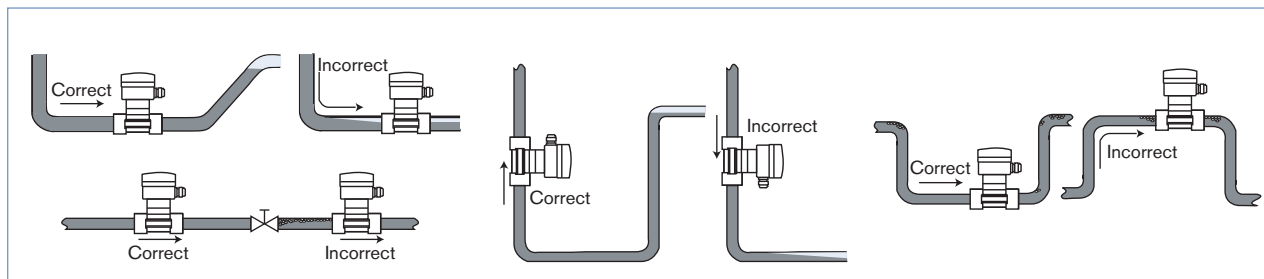

Pressure and temperature ratings must be respected according to the selected fitting material.

The suitable pipe size is selected using the diagram Flow/Velocity/DN.

The batch controller is not designed for gas flow measurement.

Pressure/Temperature diagram

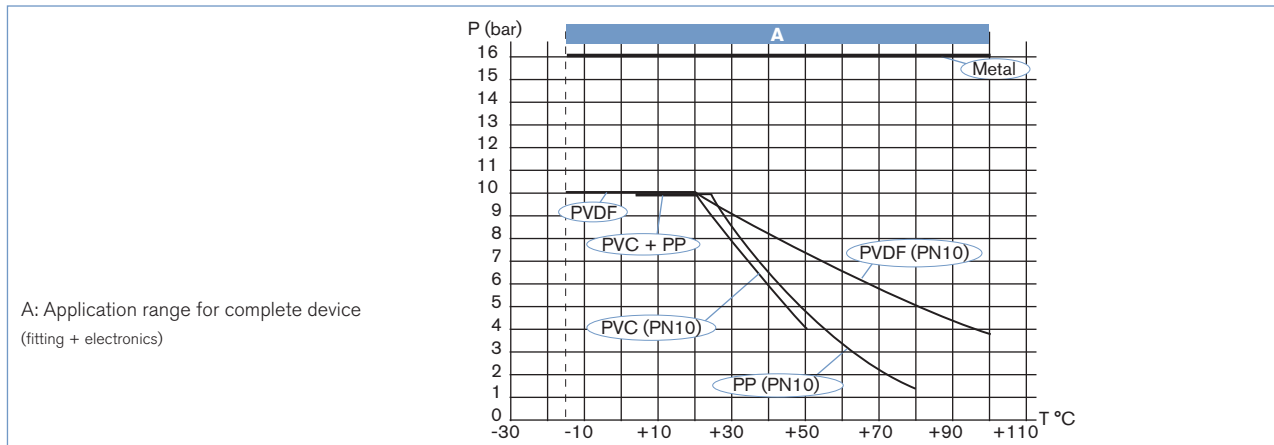

Flow/Velocity/DN Diagram

Example:

- Specification of nominal flow: 10 m³/h
- Ideal flow velocity: 2...3 m/s

For these specifications, the diagram indicates a pipe size of DN40 [or DN50 for (*) mentioned fittings]

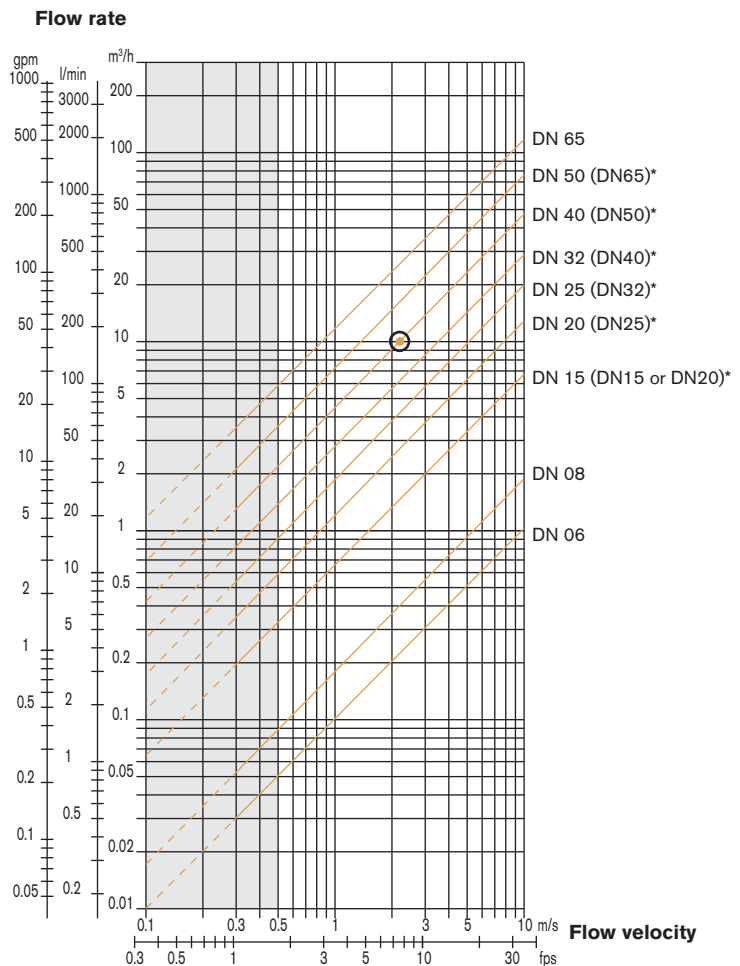

- * for following fittings with:
 - external threads acc. to SMS 1145
 - weld ends acc. to SMS 3008, BS 4825 / ASME BPE or DIN 11850 Series 2
 - Clamp acc. to SMS 3017/ ISO 2852, BS 4825 / ASME BPE or DIN 32676

Dimensions [mm]

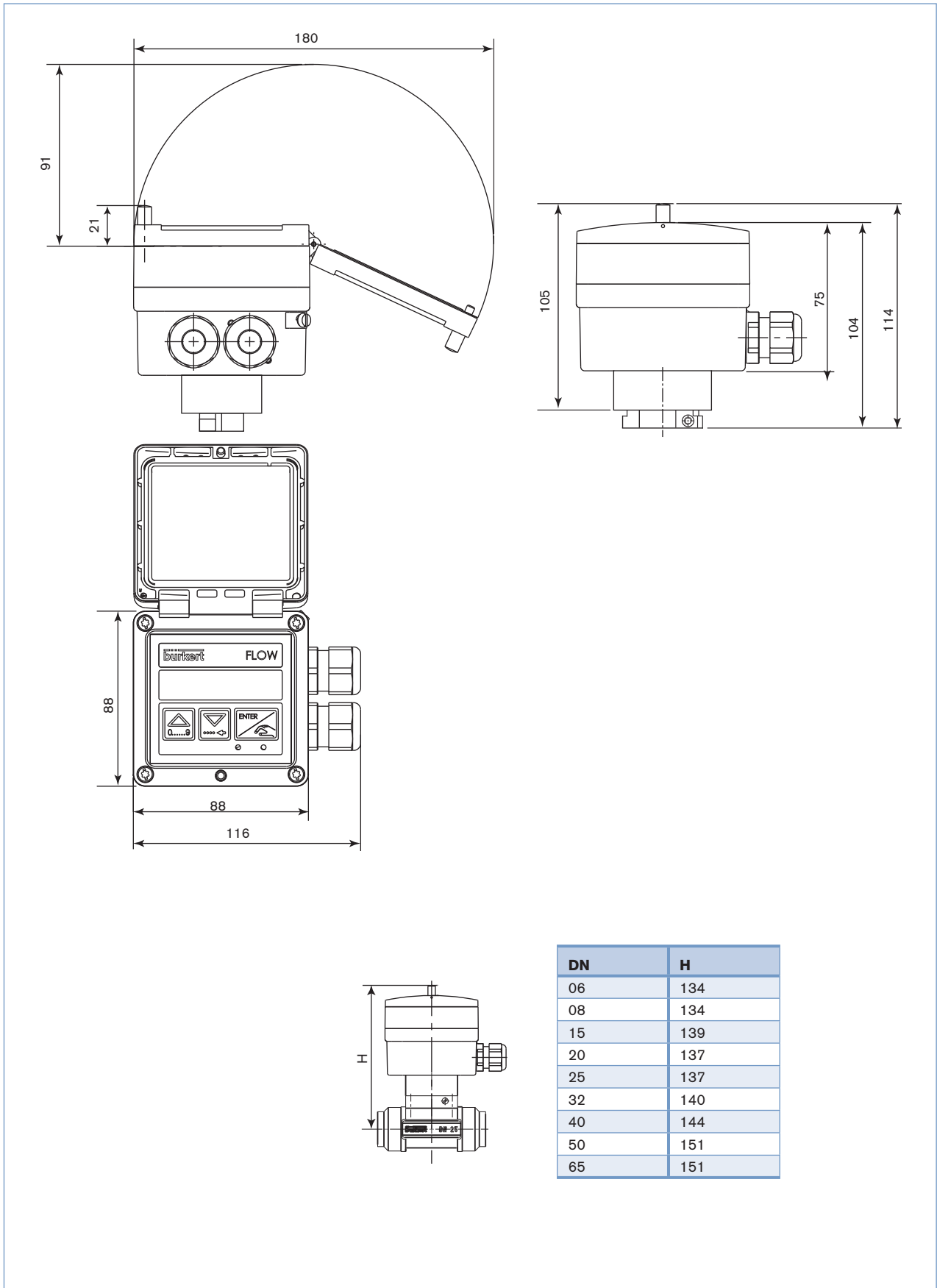

Ordering chart for batch controller Type 8035

Batch controller with integrated paddle-wheel sensor

A batch controller Type 8035 consists of:

- an INLINE electronics Type SE35
- an INLINE fitting Type S030 (DN06 - DN65) (Refer to corresponding data sheet - has to be ordered separately)

Specifications	Voltage supply	Relays	Sensor version	Electrical connection	Item no.
2 totalizers	12-30 V DC	2	Hall	2 cable glands	443 360
	115/230 V AC	2	Hall	2 cable glands	423 926

NOTE: For remote version, please refer to data sheet Type 8025 Batch controller

Ordering chart - accessories for batch controller Type 8035 (has to be ordered separately)

Specifications	Item no.
Set with 2 cable glands M20x1.5 + 2 neoprene flat seals for cable gland or plug + 2 screw-plugs M20x1.5 + 2 multiway seals 2x6 mm	449 755
Set with 2 reductions M20x1.5 /NPT1/2" + 2 neoprene flat seals for cable gland or plug + 2 screw-plugs M20x1.5	551 782
Set with 1 stopper for unused cable gland M20x1.5 + 1 multiway seal 2x6 mm for cable gland + 1 black EPDM gasket for the sensor + 1 mounting instruction sheet	551 775

Interconnection possibilities with other Bürkert products



To find your nearest Bürkert facility, click on the orange box →

www.burkert.com

In case of special application conditions, please consult for advice.

Subject to alteration.
© Christian Bürkert GmbH & Co. KG

1110/10_EU-en_00891787