

2/2-way Globe Control Valve, flange connection, DN 10-100



- Classic design with interchangeable trims, 3 to 5 Kvs-value per connection port
- Excellent control characteristic
- Ultra compact design
- Standard International face-to-face dimensions
- High operative safety

Type 2712 can be combined with...



Type 8692/8693
Positioner / Process Controller TopControl



Type 8694
Positioner TopControl Basic



Type 8630
Positioner TopControl



Type 8635
Positioner SideControl



Type 8792/93
SideControl Remote versions



Type 8030
Flow sensor

The 2712 system has been specifically engineered for reliable control in applications where control accuracy is paramount. The valve is made from an all stainless steel valve body combined with Burkert's classic pneumatic actuator. Each globe valve body can be fitted with three to five sizes of trim sets. These parabolic trims provide a reliable and repeatable characteristic to vary the flow. The control cones are available in either stainless steel or with a durable PTFE seal for tight shut-off. When actuated by the 8635 SideControl, SideControls 8792/93 Remote versions or the 8694/8692/8693/ 8630 TopControl it forms a unique control valve system which can be operated as either a simple accurate positioner or an autotune PID process controller for flow, temperature or pressure.

Proven Applications

- Fine chemical pressure and flow control
- High accuracy test bench equipment
- Food, beverage and pharmaceutical CIP/ SIP and auxiliary processes with steam
- Pharmaceutical Sterilizers
- Precision distillation apparatus
- Sterile Packaging Machinery

Technical data	
Materials	
Body	Cast stainless steel 316L (conform to 1.4409)
Actuator	PA polyamide (PPS on request)
Sealing	St.st./St.st. (stainless steel/stainless steel) PTFE/St.st. (PTFE/stainless steel)
Seat leakage IEC 534-4/EN 1349	Shut-off class IV for St.st./St.st. Shut-off class VI for PTFE/St.st.
Process media gases and liquids (vacuum version on request)	For neutral gases, water, alcohols, oils, fuels, hydraulic liquids, salt solutions, lyes, organic solvents, steam (10 bar/+180°C)
Viscosity	Max. 600 mm ² /s
Packing gland	PTFE V-rings (silicone grease) with spring compensation
Nominal pressure	PN 25 (body)
Temperatures	
Fluid	-10°C to +180°C ¹⁾ (max. +130°C for PTFE/St.st. sealing recommended)
Ambient	-10°C to +60°C ¹⁾ Actuators 80 to 125 -10°C to +50°C Actuators 175 and 225
Control medium	Compressed air
Pilot pressure	5.5 to 7 bar Actuators 80 to 125 5 to 6 bar Actuators 175 and 225
Pilot air ports	G 1/4 stainless steel (St.st.)
Flow direction	Below seat
Interchangeable seat	Different Kvs-values per port size, see table p. 2
Control ratio (Kvs/KvO)	50:1 25:1 for orifice DN6 10:1 for orifice DN4

¹⁾ high temperature on request

continued next page

Content

Valve specifications	System spec. Continuous Classic	Request for quotation
Type 2712 flange	Type 8802-GB	Type 8802-GB
Technical data & ordering info. p. 1-12	Ordering info. & technical data p. 13-17	p. 18

Technical data, continued

Technical data		
Port connections		
Flange	DIN	• DIN EN 1092-1 (DIN 2634 R ²⁾ face-to-face EN 558-1 (DIN 3202)
	ANSI	• ASME B16.5 RF ²⁾ Class 150 face-to-face EN 558-2 (ISA S75.03)
	JIS	• JIS B2238 ordinary type JIS 10K RF ²⁾ face-to-face JIS B2002 series 20 (ANSI B16.10) (EN 558-2)
Mounting position		Any, preferably upright

²⁾ Raised face (RF)

Kvs values

Port size (flange) [mm]	Actuator size [mm]	Orifice DN (seat) [mm]												
		04	06	08	10	15	20	25	32	40	50	65	80	100
10	80	0.5	1.2	2.0	2.7	–	–	–	–	–	–	–	–	–
15	80	0.5	1.2	2.1	3.1	4.3	–	–	–	–	–	–	–	
20	80	–	–	–	3.2	5.2	7.1	–	–	–	–	–	–	
25	80	–	–	–	–	5.3	7.2	12.0	–	–	–	–	–	
32	100	–	–	–	–	–	8.0	13.0	17.8	–	–	–	–	
40	100	–	–	–	–	–	–	13.6	20.2	23.8	–	–	–	
50	125	–	–	–	–	–	–	–	21.0	24.6	37.0	–	–	
65	125	–	–	–	–	–	–	–	–	17.5	26.0	52.0	–	
	175	–	–	–	–	–	–	–	–	25.5	39.5	62.0	–	
80	225	–	–	–	–	–	–	–	–	–	42.0	70.0	100	
100	225	–	–	–	–	–	–	–	–	–	–	75.0	115	

Flow curve and description

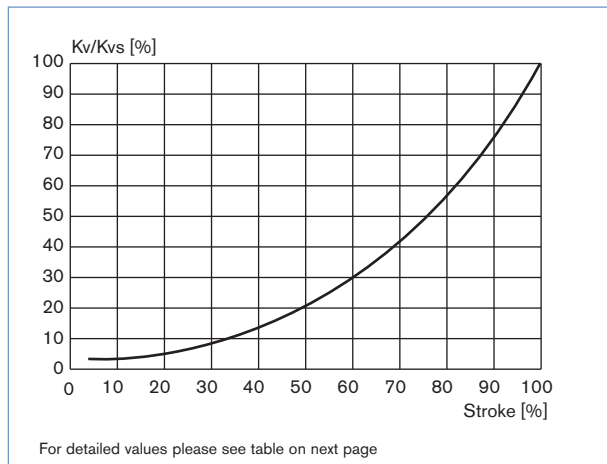

Remarks on the flow characteristic

- Equipercentile parabolic plug for the orifices DN8...DN100
- Linear plug for the orifices DN4 and DN6
- Flow characteristic runs within DIN/IEC 534-2-4
- Theoretical control ratio (Kvs/Kvo):
 - 50:1 for the orifices DN8...DN100
 - 25:1 for the orifice DN6
 - 10:1 for the orifice DN4
- KVR value at 5% of stroke for $DN > 10$ mm
KVR value at 10% of stroke for $DN \leq 10$ mm

(KVR value = smallest Kv value at which the gradient tolerance to DIN/IEC 534-2-4 is still complied with)

Technical data, continued

Kvs values [m³/h]

Port size (flange)		Orifice (seat)		Actuator size [mm]	Stroke [%]										
[mm]	[inch]	[mm]	[inch]		5	10	20	30	40	50	60	70	80	90	100
10	3/8"	4	1/8"	80	0.04	0.05	0.10	0.16	0.22	0.27	0.32	0.36	0.40	0.44	0.50
		6	3/16"	80	0.05	0.12	0.32	0.48	0.62	0.76	0.88	0.98	1.07	1.13	1.20
		8	1/4"	80	0.06	0.07	0.09	0.12	0.18	0.26	0.42	0.61	0.92	1.50	2.00
		10	3/8"	80	0.09	0.11	0.13	0.19	0.30	0.48	0.73	1.00	1.60	2.3	2.7
15	1/2"	4	1/8"	80	0.04	0.05	0.10	0.16	0.22	0.27	0.32	0.36	0.40	0.44	0.50
		6	3/16"	80	0.05	0.12	0.32	0.48	0.62	0.76	0.88	0.98	1.07	1.13	1.20
		8	1/4"	80	0.07	0.08	0.11	0.13	0.19	0.27	0.43	0.63	0.95	1.60	2.1
		10	3/8"	80	0.09	0.11	0.15	0.19	0.31	0.49	0.75	1.10	1.70	2.5	3.1
		15	1/2"	80	0.14	0.17	0.22	0.35	0.52	0.80	1.20	1.80	2.7	3.7	4.3
20	3/4"	10	3/8"	80	0.11	0.12	0.16	0.20	0.33	0.52	0.77	1.20	1.8	2.6	3.2
		15	1/2"	80	0.14	0.17	0.22	0.35	0.52	0.80	1.20	1.80	2.9	4.0	5.2
		20	3/4"	80	0.20	0.25	0.30	0.45	0.70	1.10	1.60	2.4	3.5	5.2	7.1
25	1"	15	1/2"	80	0.14	0.17	0.22	0.35	0.52	0.80	1.20	1.80	2.9	4.1	5.3
		20	3/4"	80	0.20	0.25	0.31	0.47	0.70	1.10	1.60	2.5	3.8	5.4	7.2
		25	1"	80	0.35	0.38	0.65	1.00	1.50	2.2	3.4	5.1	7.0	9.4	12.0
32	1 1/4"	20	3/4"	100	0.22	0.25	0.35	0.50	0.75	1.10	1.60	2.5	3.8	5.8	8.0
		25	1"	100	0.40	0.47	0.73	1.10	1.60	2.5	3.7	5.4	7.5	10.3	13.0
		32	1 1/4"	100	0.48	0.60	0.85	1.30	2.1	3.1	4.5	6.8	10.2	14.0	17.8
40	1 1/2"	25	1"	100	0.40	0.50	0.75	1.10	1.70	2.6	3.8	5.6	8.0	10.7	13.6
		32	1 1/4"	100	0.48	0.60	0.85	1.30	2.1	3.2	4.6	6.9	11.0	15.0	20.2
		40	1 1/2"	100	0.60	0.70	1.10	1.70	2.7	4.0	6.0	9.2	13.8	18.2	23.8
50	2"	32	1 1/4"	125	0.48	0.60	0.90	1.30	2.1	3.2	4.6	6.9	11.6	16.0	21.0
		40	1 1/2"	125	0.60	0.70	1.00	1.70	2.6	4.0	5.9	9.2	14.0	18.9	24.6
		50	2"	125	0.90	1.10	1.90	2.9	4.5	6.8	10.5	15.5	22.0	29.3	37.0
65	2 1/2"	40	1 1/2"	125	0.45	0.65	0.95	1.30	1.90	2.8	4.00	5.50	7.8	11.7	17.5
		50	2"	125	0.70	1.00	1.60	2.4	3.5	4.9	6.90	9.80	14.1	19.9	26.0
		65	2 1/2"	125	0.80	1.30	2.1	3.2	5.5	9.1	14.7	24.5	37.6	45.6	52.0
		40	1 1/2"	175	0.45	0.55	0.85	1.30	2.0	3.1	4.60	6.80	10.7	17.2	25.5
		50	2"	175	0.75	0.90	1.50	2.3	3.5	4.9	7.1	11.0	17.5	26.0	39.5
		65	2 1/2"	175	1.10	1.40	2.1	3.2	4.9	8.0	12.0	18.5	31.5	46.5	62.0
80	3"	50	2"	225	0.85	1.00	1.50	2.3	3.5	5.0	7.1	10.5	16.0	25.0	42.0
		65	2 1/2"	225	1.40	1.70	2.5	3.8	5.7	8.2	12.2	19.5	32.5	50.0	70.0
		80	3"	225	2.1	2.6	4.2	7.0	10.5	16.0	25.0	40.0	60.0	83.0	100
100	4"	65	2 1/2"	225	1.40	1.70	2.6	3.8	5.7	8.3	12.6	20.0	32.0	51.0	75.0
		80	3"	225	2.1	2.6	4.3	7.0	11.0	17.0	26.5	44.0	65.0	89.0	115
		100	4"	225	3.2	3.9	5.7	9.0	13.5	20.5	32.0	51.0	83.0	118	140

DTS 1000010998 EN Version: K validé printed: 16.04.2012 Status: RL (released | freigegeben |

Ordering chart for Globe Valve

DIN EN 1092-1 (DIN 2634), face-to-face EN 558-1 (DIN 3202), flow below seat

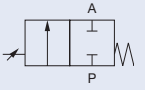
Control function	Port size (flange) [mm]	Orifice DN (seat) [mm]	Actuator size Ø [mm]	Operating pressure ≤ +180°C [bar]	Item no. seal system St.st./St.st.*	Item no. seal system PTFE/St.st.*
 <p>2/2-way, NC by spring return</p>	10	4	80	16.0	146 646	-
		6	80	16.0	156 253	-
		8	80	16.0	146 669	146 955
		10	80	16.0	146 691	146 979
	15	4	80	16.0	146 658	-
		6	80	16.0	156 261	-
		8	80	16.0	146 681	146 967
		10	80	16.0	146 703	146 991
	20	15	80	16.0	146 731	147 019
		10	80	16.0	146 717	147 005
		15	80	16.0	146 745	147 033
	25	20	80	16.0	146 773	147 061
		20	80	16.0	146 759	147 047
		25	80	16.0	146 787	147 075
	32	25	80	16.0	146 813	147 101
		20	100	16.0	146 801	147 089
		25	100	16.0	146 825	147 115
	40	32	100	16.0	146 851	147 141
		25	100	16.0	146 837	147 127
		32	100	16.0	146 863	147 153
	50	40	100	16.0	146 891	147 180
		40	125	16.0	146 877	147 166
		50	125	16.0	146 905	147 197
	65	50	125	16.0	146 200	147 211
		40	125	15.0	155 744	155 965
		50	125	15.0	147 469	156 002
		65	125	10.0	155 839	156 064
		40	175	15.0	155 764	155 985
	80	50	175	15.0	155 802	156 022
		65	175	15.0	155 860	153 878
		50	225	12.5	155 822	156 039
		65	225	12.5	155 879	156 101
100	80	225	12.5	155 914	156 134	
	65	225	10.0	155 896	156 116	
	80	225	10.0	155 931	156 150	
		100	225	10.0	155 277	156 167

*seal system: • St.st./St.st.: plug stainless steel/seat stainless steel
 • PTFE/St.st.: (soft sealing) plug PTFE/seat stainless steel

Further versions on request



Pressure

Valves with port size 65-100 mm for an operating pressure up to 16 bar



Material

Actuator: PPS for actuator sizes Ø 80-125 mm



Control function

B (NO) normally open by spring return

Ordering chart for Globe valve, continued

ASME B16.5 Class 150, face-to-face EN 558-2 (ISA S75.03), flow below seat

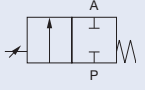
Control function	Port size (flange)		Orifice DN (seat)		Actuator size Ø [mm]	Operating pressure ≤ +180°C [bar]	Item no. seal system St.st./St.st.*	Item no. seal system PTFE/St.st.*
	[mm]	[inch]	[mm]	[inch]				
 <p>2/2-way, NC by spring return</p>	15	1/2"	4	1/8"	80	16.0	461 491	-
			6	3/16"	80	16.0	461 492	-
			8	1/4"	80	16.0	146 680	146 966
			10	3/8"	80	16.0	146 702	146 990
			15	1/2"	80	16.0	146 730	147 018
	20	3/4"	10	3/8"	80	16.0	146 716	147 004
			15	1/2"	80	16.0	146 744	147 032
			20	3/4"	80	16.0	146 772	147 060
	25	1"	15	1/2"	80	16.0	146 758	147 046
			20	3/4"	80	16.0	146 786	147 074
			25	1"	80	16.0	146 812	147 100
	40	1 1/2"	25	1"	100	16.0	146 836	147 126
			32	1 1/4"	100	16.0	146 862	147 152
			40	1 1/2"	100	16.0	146 890	147 179
	50	2"	32	1 1/4"	125	16.0	146 876	147 165
			40	1 1/2"	125	16.0	146 904	147 196
			50	2"	125	16.0	146 918	147 210
	65	2 1/2"	40	1 1/2"	125	16.0	155 743	155 964
			50	2"	125	16.0	155 782	156 001
			65	2 1/2"	125	10.0	155 838	156 063
			40	1 1/2"	175	16.0	155 763	155 984
			50	2"	175	16.0	155 801	156 021
	80	3"	65	2 1/2"	175	16.0	155 859	156 084
			50	2"	225	16.0	155 821	156 038
			65	2 1/2"	225	16.0	155 878	156 100
	100	4"	80	3"	225	16.0	154 642	156 133
			80	3"	225	16.0	155 930	156 149
			100	4"	225	16.0	154 643	156 166

*seal system: • St.st./St.st.: plug stainless steel/seat stainless steel

• PTFE/St.st.: (soft sealing) plug PTFE/seat stainless steel

 Further versions on request
**Material**

Actuator: PPS for actuator sizes Ø 80-125 mm

**Control function**

B (NO) normally open by spring return

Ordering chart for Globe valve, continued

JIS B2238 ordinary type; JIS 10K, face-to-face JIS B2002 serie 20 (ANSI B16.10) (EN 558-2), flow below seat

Control function	Port size (flange) [mm]	Orifice DN (seat) [mm]	Actuator size Ø [mm]	Operating pressure ≤ +180°C [bar]	Item no. seal system St.st./St.st.*	Item no. seal system PTFE/St.st.*
A 2/2-way, NC by spring return	15	4	80	16.0	506 641	-
		6	80	16.0	506 644	-
		8	80	16.0	148 415	148 496
		10	80	16.0	148 421	148 502
		15	80	16.0	148 430	148 510
	20	10	80	16.0	148 426	148 506
		15	80	16.0	148 434	148 514
		20	80	16.0	148 443	148 522
	25	15	80	16.0	148 438	148 518
		20	80	16.0	148 447	148 526
		25	80	16.0	148 455	148 534
	32	20	100	16.0	151 473	148 530
		25	100	16.0	148 459	148 538
		32	100	16.0	148 468	148 546
	40	25	100	16.0	148 463	148 542
		32	100	16.0	148 472	148 550
		40	100	16.0	148 481	148 558
	50	32	125	16.0	148 477	148 554
		40	125	16.0	148 485	148 562
		50	125	16.0	148 489	148 566
	65	40	125	16.0	155 745	155 966
		50	125	16.0	155 783	156 003
		65	125	10.0	155 840	156 065
		40	175	16.0	155 765	155 986
		50	175	16.0	155 803	156 023
	80	65	175	16.0	155 862	156 085
		50	225	16.0	155 823	156 040
		65	225	16.0	155 880	156 102
100	80	225	16.0	155 915	156 135	
	65	225	16.0	155 897	156 117	
	80	225	16.0	155 932	156 151	
		100	225	16.0	155 948	156 168

*seal system: • St.st./St.st.: plug stainless steel/seat stainless steel
 • PTFE/St.st.: (soft sealing) plug PTFE/seat stainless steel

i Further versions on request



Material

Actuator: PPS for actuator sizes Ø 80-125 mm



Control function

B (NO) normally open by spring return

Materials

DN 10-65 (actuator sizes 80 to 125 mm)

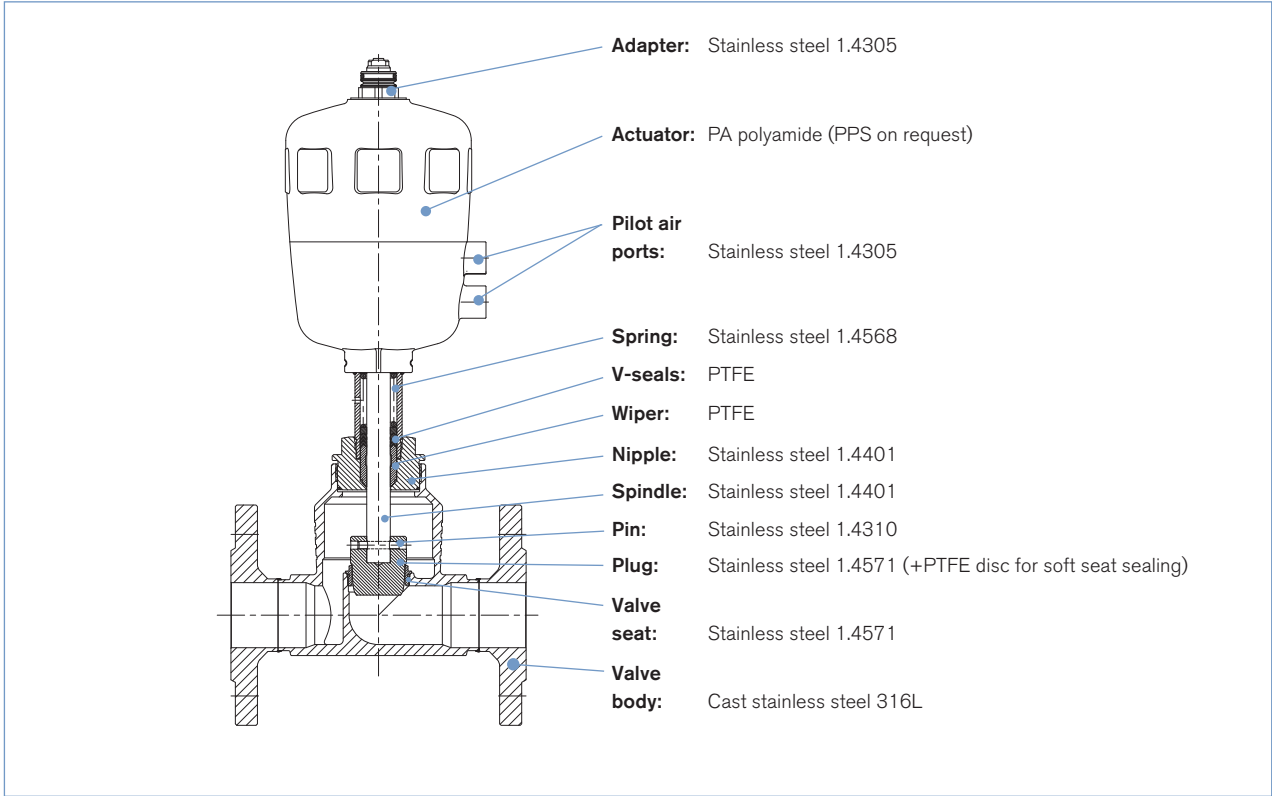

DN 65-100 (actuator sizes 175 and 225 mm)

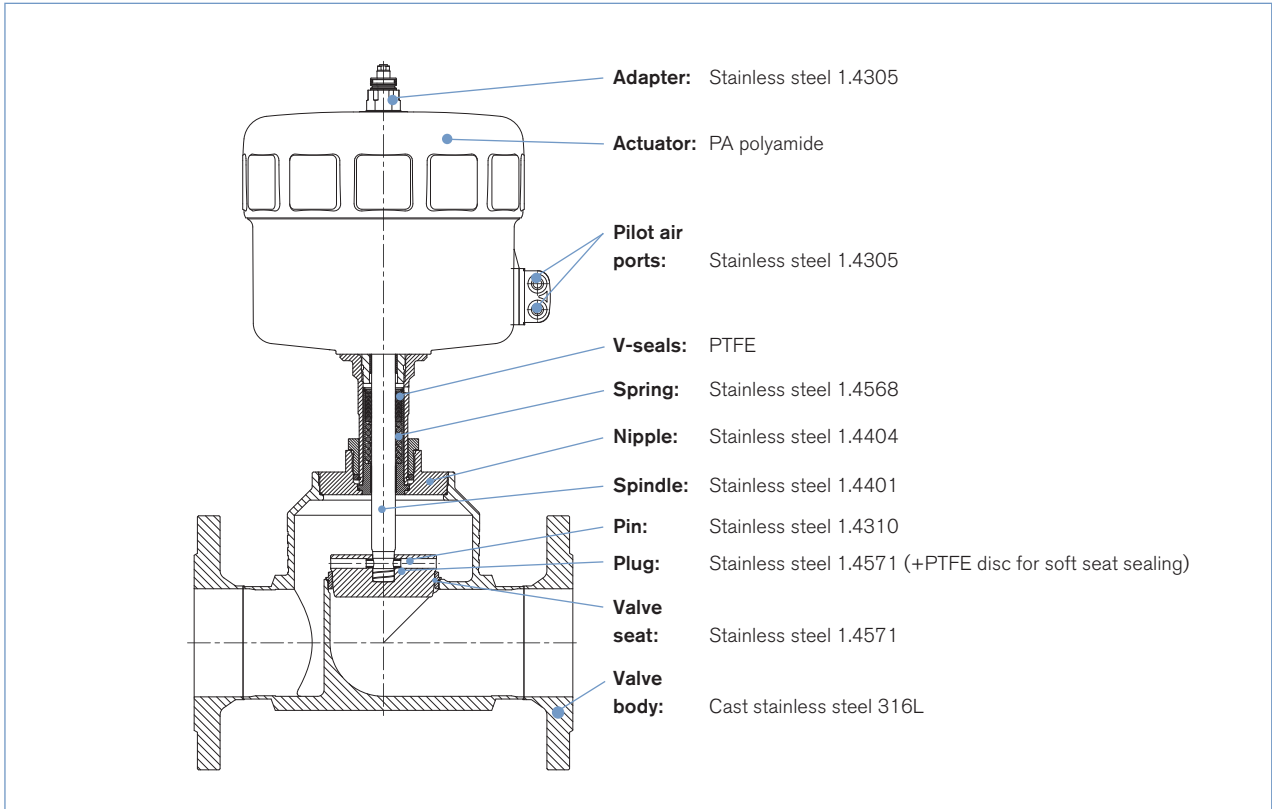

Dimensions [mm]

DN 10-65

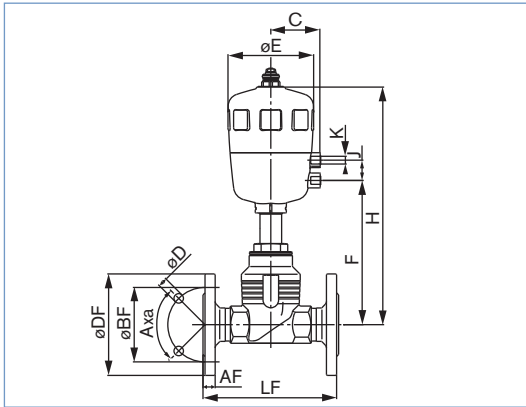

Angles Ax α			
Port size [mm]	DIN flange	ANSI flange	JIS flange
10	4x90°	4x90°	4x90°
15	4x90°	4x90°	4x90°
20	4x90°	4x90°	4x90°
25	4x90°	4x90°	4x90°
32	4x90°	4x90°	4x90°
40	4x90°	4x90°	4x90°
50	4x90°	4x90°	4x90°
65	8x45°	4x90°	4x90°

All actuators		DIN flange						ANSI flange					JIS flange										
Port size [mm]	Actuator size	C	øE	F	H	K	J	øDF	LF	øBF	AF	øD	øDF	LF	øBF	AF	øD	øDF	LF	øBF	AF	øD	
10	80	60	101	166	264	G 1/4	24	90	130	60	16	14	-	-	-	-	-	-	-	-	-	-	-
15	80	60	101	166	264	G 1/4	24	95	130	65	16	14	89.0	184	60.5	11.2	15.7	95	108	70	12	15	
20	80	60	101	160	259	G 1/4	24	105	150	75	18	14	99.0	184	69.9	12.7	15.7	100	117	75	14	15	
25	80	60	101	164	262	G 1/4	24	115	160	85	18	14	108.0	184	79.2	14.2	15.7	125	127	90	14	19	
32	100	73	127	208	346	G 1/4	30	140	180	100	18	18	-	-	-	-	-	135	140	100	16	19	
40	100	73	127	214	351	G 1/4	30	150	200	110	18	18	127.0	222	98.6	17.5	15.7	140	165	105	16	19	
50	125	86	157	225	388	G 1/4	30	165	230	125	20	18	152.0	254	120.7	19.1	19.1	155	203	120	16	19	
65	125	86	157	254	417	G 1/4	30	185	290	145	22	18	178.0	276	139.7	22.3	19.1	175	216	140	18	19	

DN 65-100

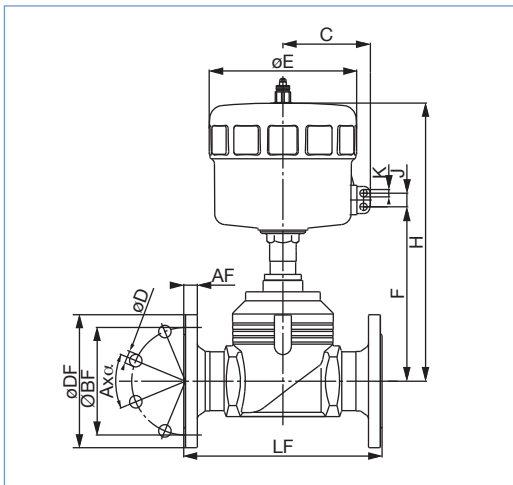

Angles Ax α			
Port size [mm]	DIN flange	ANSI flange	JIS flange
65	8x45°	4x90°	4x90°
80	8x45°	4x90°	4x90°
100	8x45°	8x45°	8x45°

All actuators		DIN flange						ANSI flange					JIS flange									
Port size [mm]	Actuator size	C	øE	F	H	K	J	øDF	LF	øBF	AF	øD	øDF	LF	øBF	AF	øD	øDF	LF	øBF	AF	øD
65	175	130	211	289	479	G 1/4	24	185	290	145	22	18	178.0	276	139.7	22.3	19.1	175	216	140	18	19
80	225	155	261	299	482	G 1/4	24	200	310	160	24	18	190.0	298	152.4	23.9	19.1	185	241	150	18	19
100	225	155	261	309	492	G 1/4	24	235	350	190	24	22	229.0	352	190.5	23.9	19.1	210	292	175	18	19

Spare parts for Type 2712 – DN 10-100 (on request)

Port size 10-65 in combination with actuator size 80 to 125 mm

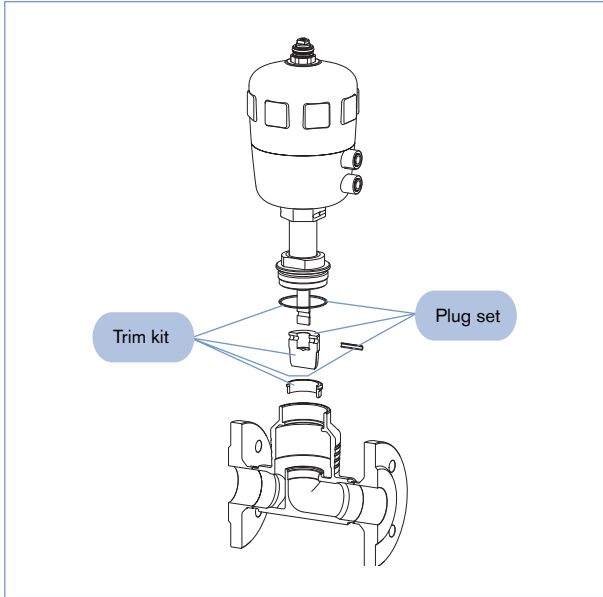

Port size 65-100 in combination with actuator size 175 and 225 mm

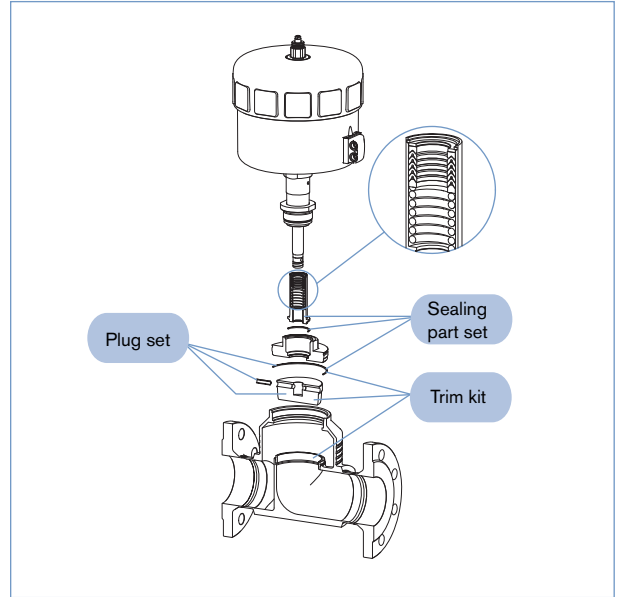

Further process connections

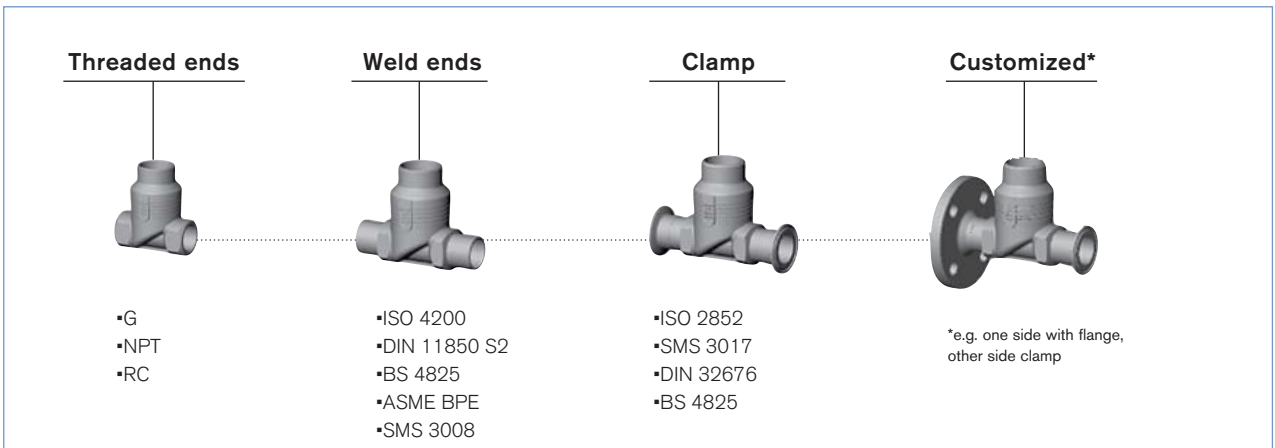

Ordering information for valve system Continuous Classic Type 8802-GB

A valve system Continuous Classic Type 8802-GB consists of an globe control valve Type 2712 and a digital electropneumatic Positioner Type 8692, a digital electropneumatic Process Controller Type 8693, a digital electropneumatic Positioner Basic Type 8694 (below) or a valve actuation system TopControl Type 8630, SideControl Type 8635 or an electropneumatic positioner Type 8792/8793 (next page) (see separate datasheets). For the configuration of further valve systems please use the "Request for quotation" on p. 15 [go to page](#)
You order two components and receive a complete assembled and certified valve.

Ordering the valve system Continuous Classic Type 8802-GB

Globe control valve
Type 2712



Positioner



Positioner
Type 8692



Process Controller
Type 8693



Positioner Basic
Type 8694

Globe control valve
with desired control unit



Valve system
Continuous
Classic
Type 8802-GB-I
2712 + 8692



Valve system
Continuous
Classic
Type 8802-GB-J
2712 + 8693



Valve system
Continuous
Classic
Type 8802-GB-L
2712 + 8694

When you click on the orange box "More info." below, you will come to our website for the resp. product where you can download the datasheet.

Positioner TopControl
Type 8692

More info.

Process Controller
TopControl Type 8693

More info.



PROFIBUS

DeviceNet™



The new generation of integrated positioners/process controllers for combination with actuators from the process valve series Type 23xx/2103 is specially designed for the requirements of hygienic process environments. The easy handling and the selection of additional software functions are done either on a big graphic display with backlight and keypad or via a PC interface. A contact-free analogue position sensor registers the valve position without deterioration. Single-acting or double-acting actuators are controlled via the integral positioner system. With Type 8693, the process controller function is superimposed on the position control loop. Profibus DPV1 and DeviceNet communication interfaces are available as options. Main customer benefits:

- Compact design of the valve system with integrated positioner/process controller meets the demands for plant washdown environments through the selection of materials, external seals and integrated control air supply to the actuator
- Extremely simple commissioning and operation thanks to the back-lighting of the graphics display and proven multilingual software structure
- Automatic parameterisation of the positioner and process controller using the TUNE functions
- Field bus communication via Profibus DPV1 or DeviceNet
- Air intake filter enhances the process valve system availability
- Simple and reliable actuator adaption
- Explosion-proof models for zone 2/22

Positioner TopControl Basic Type 8694

More info.



The new generation of integrated positioners for combination with actuators from the process valve series Type 23xx/2103 is specially designed for the requirements of hygienic process environments. The operation and selection of the software functions close tight function, inversion of the operating direction of the setpoint signal, characteristic curves selection and switching manual/automatic operation are effected via push-buttons and DIP switches or via the PC interface. The position setpoint is set using the standard signal 4 - 20 mA. In addition, the enable can be controlled via the binary input and an optional position feedback can be integrated. The positioner, Type 8694, registers the valve position without deterioration through a contact-free analogue position sensor. Single-acting or double-acting actuators are controlled via the integral positioner system. An AS-Interface communication interface is available as an option. Main customer benefits:

- Compact design of the valve system with integrated positioner meets the demands for plant washdown environments through the selection of materials, external seals and integrated control air supply to the actuator
- Automatic parameterisation of the process controller using the Process TUNE function
- Field bus communication via optional AS-Interface
- Air intake filter enhances the process valve system availability
- Simple and reliable actuator adaption allowing additional actuators of the process valve series, Type 20xx or actuators from other manufacturers to be used
- Explosion-proof models for zone 2/22

Ordering information for valve system Continuous Classic Type 8802-GB, continued

A valve system Continuous Classic Type 8802-GB consists of an globe control valve Type 2712 and a digital electropneumatic Positioner Type 8692, a digital electropneumatic Process Controller Type 8693, a digital electropneumatic Positioner Basic Type 8694 (previous page) or a valve actuation system TopControl Type 8630, SideControl Type 8635 or an electropneumatic positioner Type 8792/8793 (below) (see separate datasheets). For the configuration of further valve systems please use the "Request for quotation" on p. 15 [go to page](#)
You order two components and receive a complete assembled and certified valve.

Ordering the valve system Continuous Classic Type 8802-GB

Globe control valve
Type 2712



Positioner



Positioner/
Process Controller
Type 8630



Positioner/
Process Controller
Type 8635



Positioner
Type 8792/
Process
Controller
Type 8793

Globe control valve
with desired control unit



Valve system
Continuous Classic
Type 8802-GB-A
2712 + 8630



Valve system
Continuous Classic
Type 8802-GB-B
2712 + 8635



Valve system
Continuous Classic
Type 8802-GB-P
2712 + 8792 /
Type 8802-GB-Q
2712 + 8793

When you click on the orange box "More info." below, you will come to our website for the resp. product where you can download the datasheet.

TopControl Type 8630 [More info.](#)



0/4-20 mA
0-5/10 V

PROFIBUS
DeviceNet™



The Type 8630 is an electro-pneumatic positioner for usage with pneumatically operated process valves. The compact design with integrated position encoder and LCD display was developed for demanding applications of the process industry.

Main customer benefits are:

- Time saving algorithms for temperature, flow and pressure PID parameters through ProcessTUNE function.
- Quick and simple menu driven parameterization through keyboard
- Field bus communication via Profibus DPV1 or DeviceNet
- Fits seamlessly to Bürkert's process valve systems
- Break resistant housing
- Suitable for hazardous locations per zone 2 and 22

SideControl Type 8635, 2-wire, intrinsically safe [More info.](#)



4-20 mA



Type 8635 is a digital electro-pneumatic positioner with an optional, integrated process controller for precise control requirements. The compact design with integrated position encoder and LCD display was developed for demanding applications of the process industry.

Main customer benefits are:

- Time saving algorithms for temperature, flow and pressure PID parameters through ProcessTUNE function.
- Quick and simple menu driven parameterization through keyboard or Profibus PA
- Remote setpoint adjustment via a 4-20 mA signal
- Adaptation according to IEC534-6 for lift and swivel drives
- Rugged anodised aluminium housing
- Suitable for hazardous locations per zone 1, zone 21 or zone 2 and 22

Positioner SideControl Type 8792 [More info.](#)

Process Controller SideControl Type 8793 [More info.](#)



PROFIBUS



Type 8792/8793 is a digital electro-pneumatic positioner with an optional, integrated process controller (8793) for precise control requirements. The compact design with integrated position encoder and LCD display was developed for demanding applications of the process industry. A Profibus DPV1 communication interface is available as an option.

Main customer benefits are:

- Time saving algorithms for temperature, flow and pressure PID parameters through ProcessTUNE function.
- Quick and simple menu driven parameterization through keyboard or Profibus DPV1 PA
- Adaption acc. to IEC534-6 and VDI/VDE 3845 for lift and swivel drives or as a Remote version together with Bürkert process valves
- Rugged anodised aluminium housing
- Suitable for hazardous locations per zone 2/22

Dimensions for valve system Continuous Classic Type 8802-GB [mm]

Dimensions valve system Continuous Classic Type 8802-GB-I with positioner TopControl Type 8692 and 8802-GB-J with process controller TopControl Type 8693 [mm]

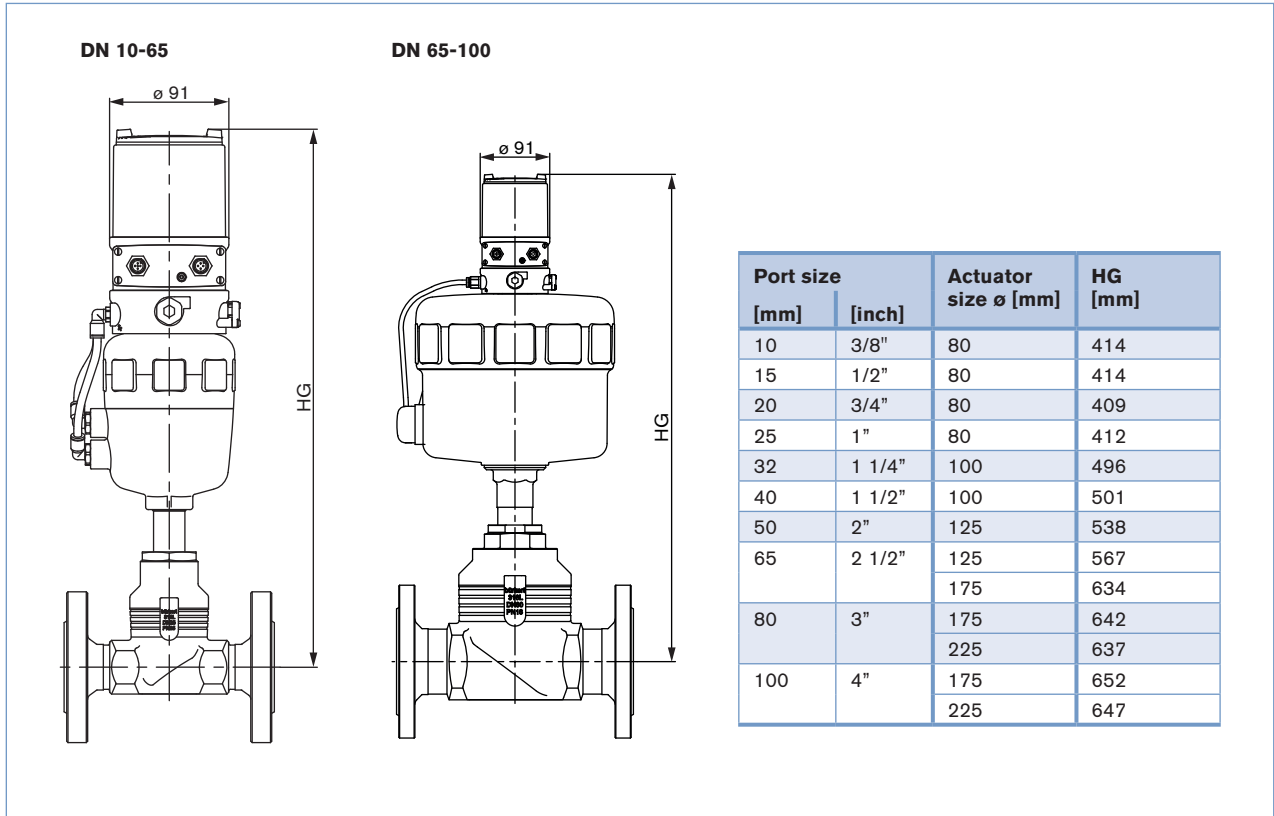

Dimensions valve system Continuous Classic Type 8802-GB-L with positioner TopControl Basic Type 8694 [mm]

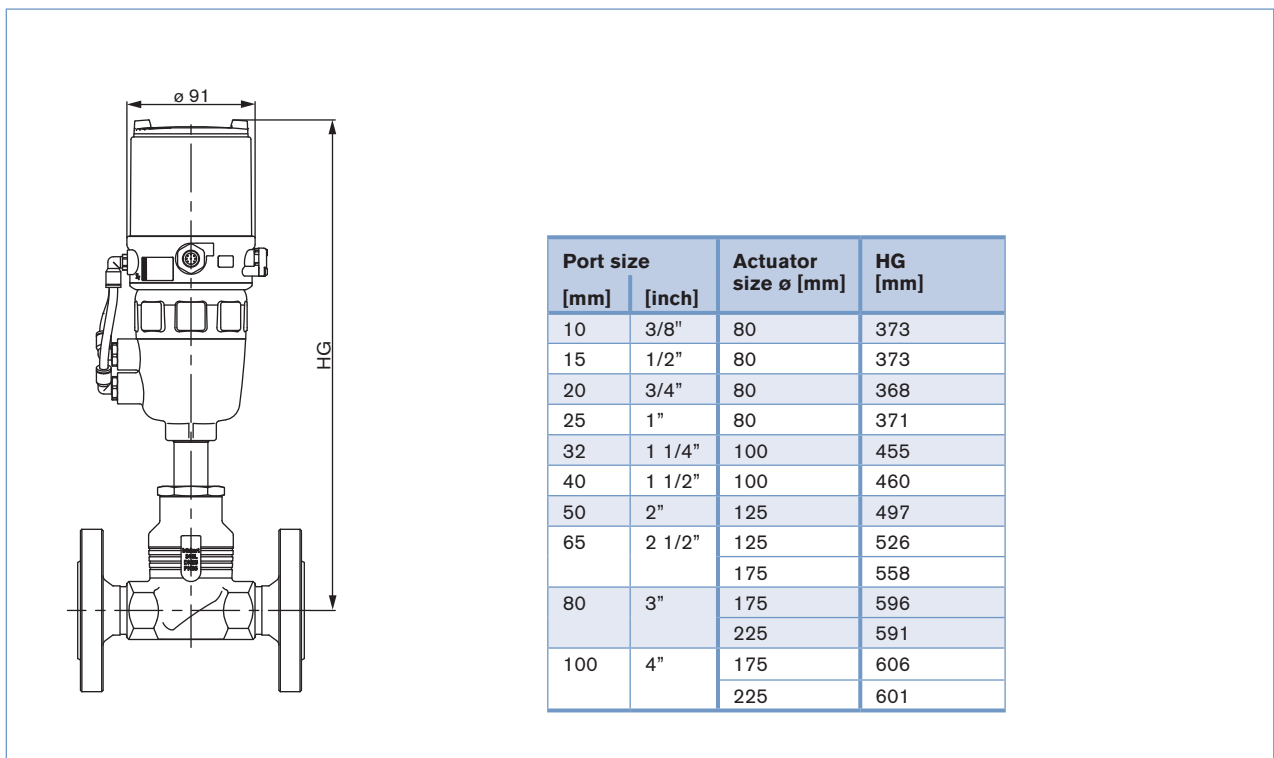

Further dimensions see p. 11

Dimensions for valve system Continuous Classic Type 8802-GB [mm], continued

Dimensions valve system Continuous Classic Type 8802-GB-A with positioner TopControl Type 8630 [mm]

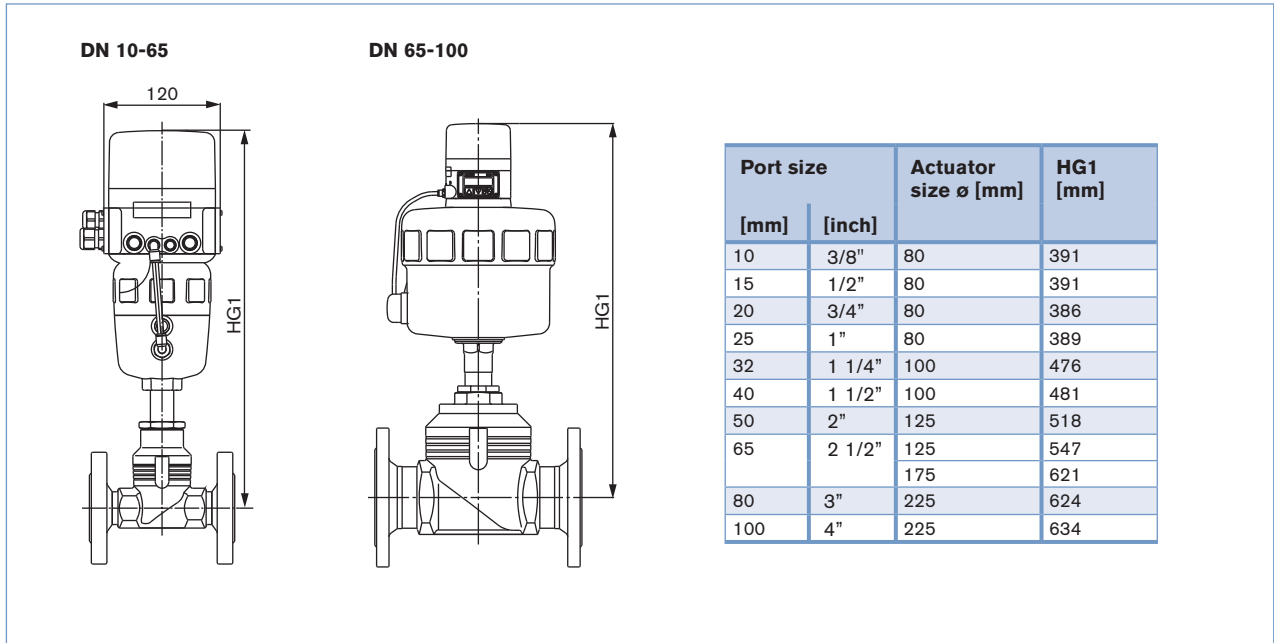

Dimensions valve system Continuous Classic 8802-GB-B with positioner SideControl Type 8635 [mm]

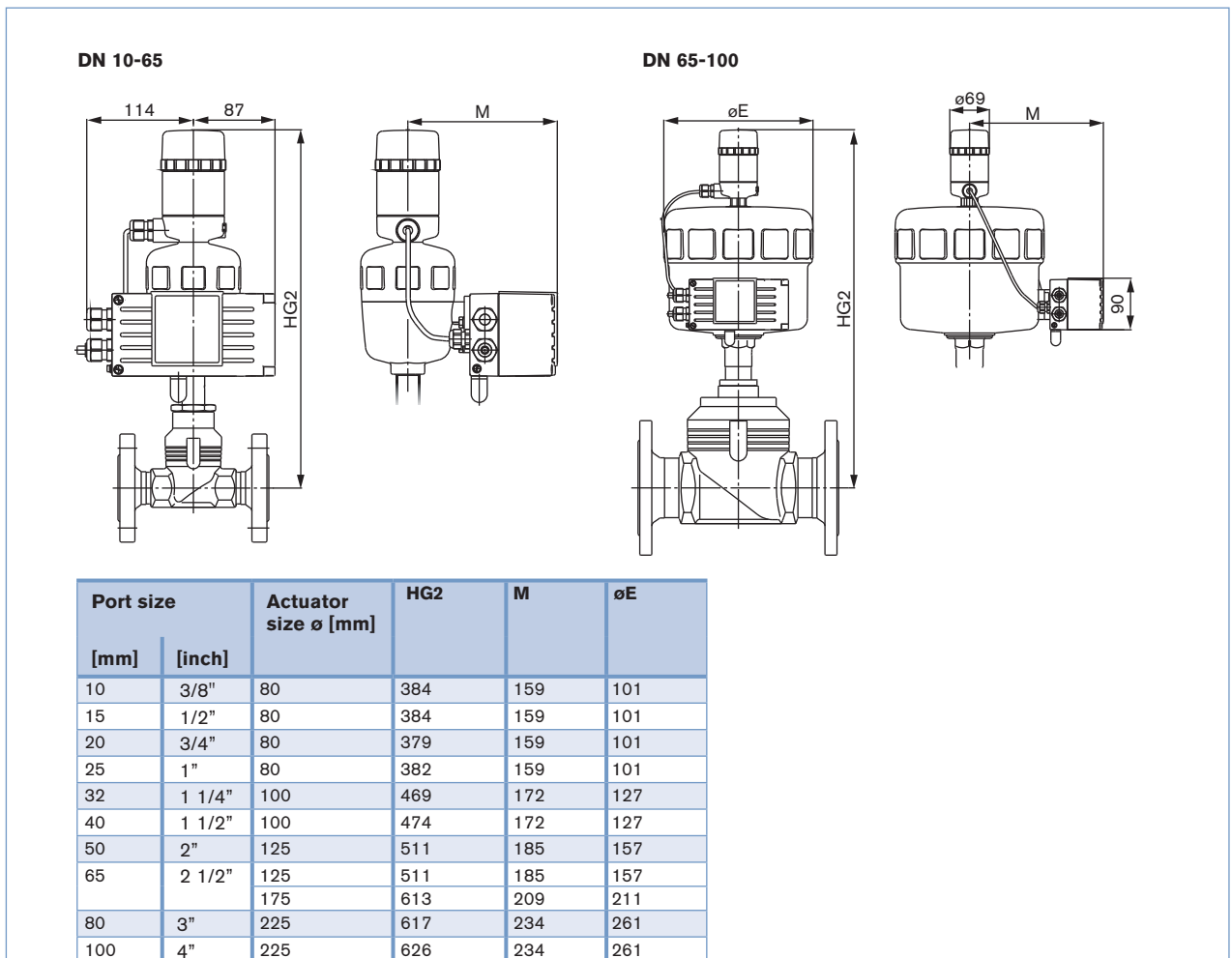

Further dimensions see p. 11

Dimensions for valve system Continuous Classic Type 8802-GB [mm], continued

Dimensions valve system Continuous Classic Type 8802-GB-P with Positioner SideControl Remote Type 8792 and Type 8802-GB-Q with Process Controller SideControl Remote Type 8793 [mm]

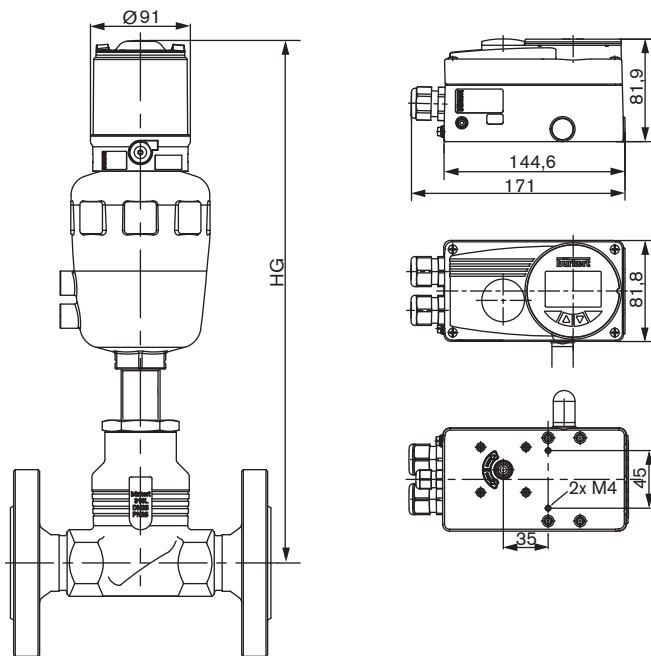

Port size		Actuator size [mm]	HG [mm]
[mm]	[inch]		
10	3/8"	80	376
15	1/2"	80	376
20	3/4"	80	371
25	1"	80	374
32	1 1/4"	100	458
40	1 1/2"	100	463
50	2"	125	500
65	2 1/2"	125	529
		175	591
80	3"	175	599
		225	594
100	4"	175	609
		225	604

Further dimensions see p. 11

Note

You can fill out the fields directly in the PDF file before printing out the form.

Valve system Continuous Classic Type 8802-GB - Request for quotation

▶ Please fill out and send to your nearest Bürkert facility* with your inquiry or order

Company	Contact person
Customer no.	Department
Address	Tel./Fax
Postcode/town	E-Mail

= mandatory fields to fill out

Quantity

Required delivery date

Operating data

Pipeline	DN	<input type="text"/>	PN	<input type="text"/>
Pipe material	<input type="text"/>			
<input checked="" type="checkbox"/> Process medium	<input type="text"/>			
<input checked="" type="checkbox"/> Type of media	<input type="checkbox"/> Liquid	<input type="checkbox"/> Steam	<input type="checkbox"/> Gas	
	min	standard	max	unit
<input checked="" type="checkbox"/> Flow rate (Q, Q _N , W) ¹⁾	<input type="text"/>	<input type="text"/>	<input type="text"/>	<input type="text"/>
<input checked="" type="checkbox"/> Temperature at valve inlet	<input type="text"/>	<input type="text"/>	<input type="text"/>	<input type="text"/>
<input checked="" type="checkbox"/> Absolute pressure at valve inlet	<input type="text"/>	<input type="text"/>	<input type="text"/>	<input type="text"/>

¹⁾ standard unit: Liquid Q = m³/h; Steam W = kg/h; Gas Q_N = nm³/h

Valve features

Actuator material	<input type="checkbox"/> PA	<input type="checkbox"/> PPS				
Body material	<input type="checkbox"/> Cast stainless steel					
Seat sealing material	<input type="checkbox"/> St.st./St.st.	<input type="checkbox"/> PTFE/St.st.				
Nominal pressure	PN	<input type="text"/>				
Nominal size	DN	<input type="text"/>				
Type of connection	<input type="checkbox"/> Flange	<input type="checkbox"/> Socket union	<input type="checkbox"/> Welded	<input type="checkbox"/> Internal thread	<input type="checkbox"/> External thread	<input type="checkbox"/> Clamp
Standard connection	<input type="checkbox"/> DIN	<input type="checkbox"/> ANSI	<input type="checkbox"/> JIS	<input type="checkbox"/> Other	<input type="text"/>	
Function	<input type="checkbox"/> NC ²⁾	<input type="checkbox"/> NO ²⁾				
Pilot pressure	<input type="text"/>	min.	<input type="text"/>	max.		
Please specify item no. if known:	<input type="text"/>					

²⁾NC: normally closed by spring action; NO: normally open by spring action

continued next page

* To find your nearest Bürkert facility, click on the orange box →

www.burkert.com

