

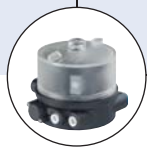

2/2-way Angle-Seat Valve with stainless steel design for medium up to +185°C, DN 13-50

- High flow rates
- High cycle life
- Flow optimised body in stainless steel
- Deliverable with flow direction below or above seat
- Clean design for optimal use in hygienic environment
- Suitable for steam up to 10 bar(g)

Type 2100 welded can be combined with...



Type 8690

Pneum. control unit with feedback



Type 8691

Control head



Type 8695

Control head



Typ 8619

MultiCELL Transmitter/Controller



Typ 8222

Conductivity transmitter

In line with Bürkert's philosophy for modular valves and sensors the construction of the 2100 angle-seat valve fulfils tough criteria for process environments. Unrivalled cycle life and sealing integrity is guaranteed by the proven self adjusting spindle packing with V-seals.

The design enables the easy integration of automation modules whether they are electrical/optical position feedback, pneumatic control units, an integrated fieldbus interface or even an explosion proof feedback.

The fully integrated system has a compact and smooth design, integrated pneumatic lines, IP65/67 protection class and superior chemical resistance.

Technical data	
Orifice	DN 13 to 50
Port connections Welded acc. to	EN ISO 1127, DIN 11850 S2, ASME BPE, SMS 3008, BS 4825
Body material Welded body -EN ISO 1127/ISO 4200 and DIN 11850 Serie 2 -ASME BPE, SMS 3008, BS 4825 Part 1	Stainless steel 1.4581 (316L on request) Stainless steel 316L
Actuator material Actuator Cover	PPS Stainless steel 1.4561 (316Ti)
Sealing material	PTFE
Medium	Water, alcohol, oils, fuels, hydraulic fluids, salt solution, alkali solutions, organic solvents, steam
Viscosity	max. 600 mm ² /s
Spindle packing	PTFE V-rings with spring compensation
Medium temperature	-10 to +185 °C
Ambient temperature	0 bis +55 °C (integrated control head) 0 bis +60 °C (push-in air ports) 0 bis +100 °C (threaded air ports)
Control medium	Neutral gases, air
Max. pilot pressure	max. 10 bar; actuator size 130mm, 7 bar
Pilot air ports	Push-in connector for external ø 6 mm or 1/4" tube, thread G1/8 (on request)
Installation	As required, preferably with actuator in upright position
Surface Finish on request	standard Ra, internal ≤ 3.2 µm Int. Ra ≤ 0.8 µm (external cast surface) electropolished Int. Ra ≤ 0.4 µm (external cast surface) electropolished

Content

Valve specifications		System spec. On/Off ELEMENT	Request for quotation
Type 2100		Type 8801-YE	
Technical data & ordering info.	p. 1-9	Ordering info. & technical data	p. 10-14
			p. 14

Technical data angle seat valve Type 2100 flow direction below the seat (for gases and liquids)

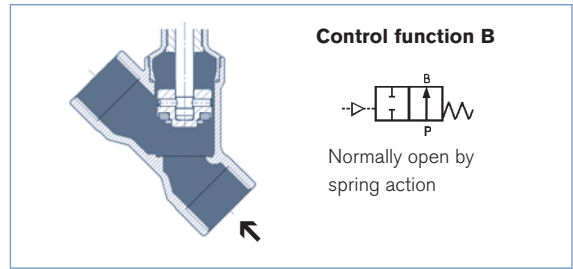
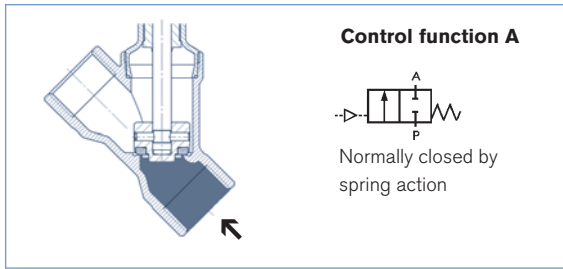

Orifice [mm]	Actuator size [mm]	Kv value water (m³/h)	Minimum pilot pressure SFA [bar]	Operating pressure up to +185°C	
				SFA [bar]	SFB [bar]
13	50	5	5.0	25	16
	70	5	5.0	25	16
20	50	11	5.0	13	16
	70	11	5.0	20	16
25	50	18	5.0	6	16
	70	18	5.0	16	16
32	70	27	5.0	8.5	16
	90	28	5.0	16	16
40	70	38	5.0	6	16
	90	40	5.0	16	16
50	70	52	-	-	16
	90	55	5.0	10	16
	130	62	5.0	16	16

Flow rate: Kv value water [m³/h]: Measured at +20 °C, 1 bar pressure at valve inlet and free outlet.

Pressure valves [bar]: Overpressure to the atmospheric pressure

Pressure charts with control function B and flow direction below the seat

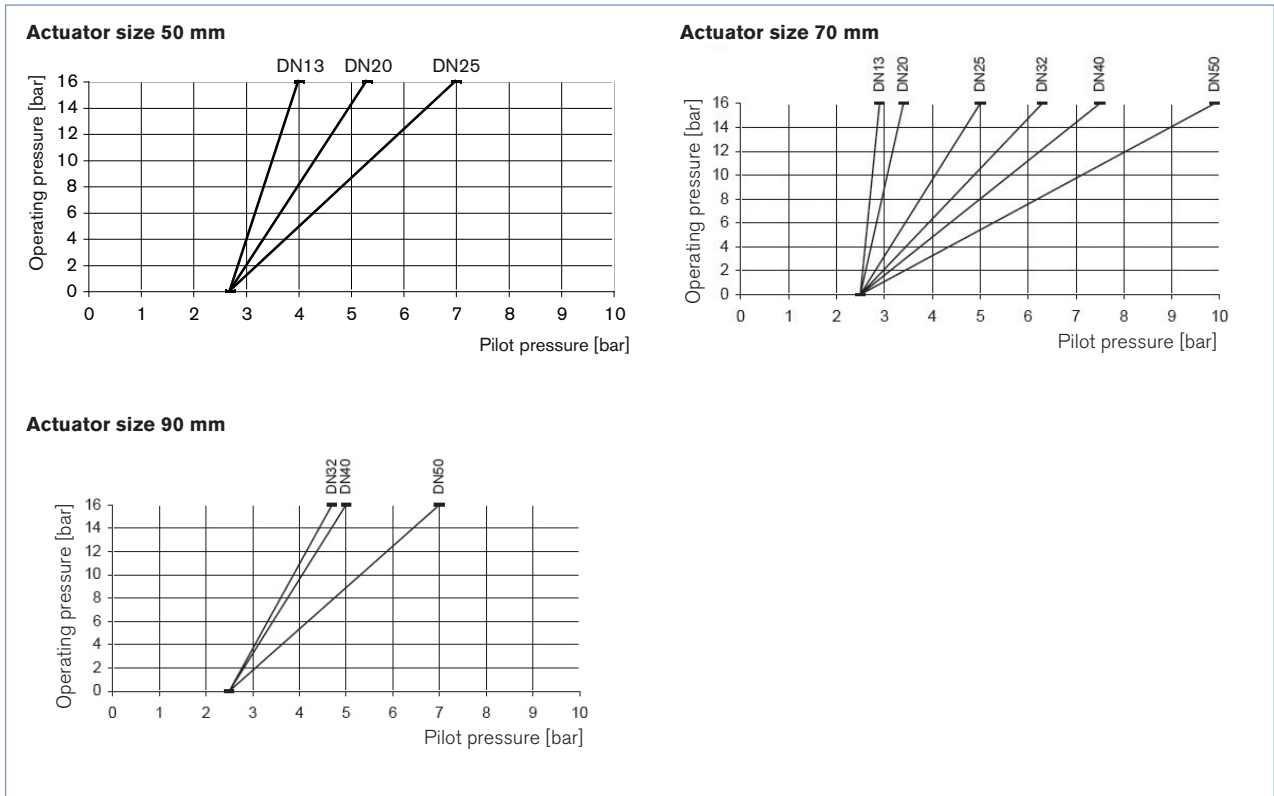

Ordering chart Type 2100, flow direction below the seat (for gases and liquids), *continued*

Weld end acc. to EN ISO 1127, flow direction below the seat

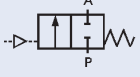
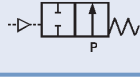
Control function	Orifice (mm)	Actuator size \varnothing [mm]	Port connection tube- \varnothing [mm]	Minimum pilot pressure [bar]	Operating pressure up to +185°C [bar]	Item no.
A 2/2-way valve, NC 	15	50	21.3 x 1.6	5.0	25	187 065
	15	70	21.3 x 1.6	5.0	25	188 680
	20	50	26.9 x 1.6	5.0	13	210 399
		70	26.9 x 1.6	5.0	20	188 681
	25	50	33.7 x 2	5.0	6	235 519
		70	33.7 x 2	5.0	16	188 682
	32	70	42.4 x 2	5.0	8.5	188 683
	32	90	42.4 x 2	5.0	16	188 684
	40	70	48.3 x 2	5.0	6	188 685
	40	90	48.3 x 2	5.0	16	188 686
	50	90	60.3 x 2.6	5.0	10	188 687
		130	60.3 x 2.6	5.0	16	188 688
B 2/2-way valve, NO 	15	50	21.3 x 1.6	see chart on p. 2	16	187 069
	15	70	21.3 x 1.6		16	188 697
	20	50	26.9 x 1.6		16	187 070
	20	70	26.9 x 1.6		16	188 698
	25	70	33.7 x 2		16	188 699
	32	70	42.4 x 2		16	188 700
	40	70	48.3 x 2		16	188 701
	50	70	60.3 x 2.6		16	188 702

Weld end acc. to DIN 11850 S2, flow direction below the seat

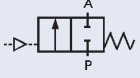
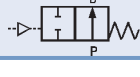
Control function	Orifice (mm)	Actuator size \varnothing [mm]	Port connection tube- \varnothing [mm]	Minimum pilot pressure [bar]	Operating pressure up to +185°C [bar]	Item no.
A 2/2-way valve, NC 	15	50	19 x 1.5	5.0	25	187 071
	15	70	19 x 1.5	5.0	25	188 703
	20	50	23 x 1.5	5.0	13	227 605
		70	23 x 1.5	5.0	20	188 704
	25	50	29 x 1.5	5.0	6	227 606
		70	29 x 1.5	5.0	16	188 705
	32	70	35 x 1.5	5.0	8.5	188 706
	32	90	35 x 1.5	5.0	16	188 707
	40	70	41 x 1.5	5.0	6	188 708
	40	90	41 x 1.5	5.0	16	188 709
	50	90	53 x 1.5	5.0	10	188 710
		130	53 x 1.5	5.0	16	188 711
B 2/2-way valve, NO 	15	50	19 x 1.5	see chart on p. 2	16	187 075
	15	70	19 x 1.5		16	188 720
	20	50	23 x 1.5		16	187 076
	20	70	23 x 1.5		16	188 721
	25	70	29 x 1.5		16	188 722
	32	70	35 x 1.5		16	188 723
	40	70	41 x 1.5		16	188 724
	50	70	53 x 1.5		16	188 725

i Further versions on request
**Material**

Body: Stainless steel 316L

**Control function**

I (double-acting)

Ordering chart Type 2100, flow direction below the seat (for gases and liquids), *continued*

Weld end acc. to ASME BPE, flow direction below the seat

Control function	Orifice (mm)	Actuator size ø [mm]	Port connection tube-Ø [mm]	Minimum pilot pressure [bar]	Operating pressure up to +185°C [bar]	Item no.
A 2/2-way valve, NC 	15	50	12.7 x 1.65	5.0	25	187 077
	15	70	12.7 x 1.65	5.0	25	188 726
	20	50	19.05 x 1.65	5.0	13	227 607
		70	19.05 x 1.65	5.0	20	188 727
	25	50	25.4 x 1.65	5.0	6	227 608
		70	25.4 x 1.65	5.0	16	188 728
	40	70	38.1 x 1.65	5.0	6	188 729
	40	90	38.1 x 1.65	5.0	16	188 730
	50	90	50.8 x 1.65	5.0	10	188 731
		130	50.8 x 1.65	5.0	16	188 732
B 2/2-way valve, NO 	15	50	12.7 x 1.65	see chart on p. 2	16	187 082
	15	70	12.7 x 1.65		16	188 740
	20	50	19.05 x 1.65		16	187 083
	20	70	19.05 x 1.65		16	188 741
	25	70	25.4 x 1.65		16	188 742
	40	70	38.1 x 1.65		16	188 743
	50	70	50.8 x 1.65		16	188 744

Weld end acc. to SMS 3008, flow direction below the seat

Control function	Orifice (mm)	Actuator size ø [mm]	Port connection tube-Ø [mm]	Minimum pilot pressure [bar]	Operating pressure up to +185°C [bar]	Item no.
A 2/2-way valve, NC 	15	50	12 x 1.0	5.0	25	187 084
	15	70	12 x 1.0	5.0	25	188 745
	20	50	18 x 1.0	5.0	13	227 609
		70	18 x 1.0	5.0	20	188 746
	25	50	25 x 1.2	5.0	6	227 610
		70	25 x 1.2	5.0	16	188 747
	40	70	38 x 1.2	5.0	6	188 748
	40	90	38 x 1.2	5.0	16	188 749
	50	90	51 x 1.2	5.0	10	188 750
		130	51 x 1.2	5.0	16	188 751
B 2/2-way valve, NO 	15	50	12 x 1.0	see chart on p. 2	16	187 089
	15	70	12 x 1.0		16	188 759
	20	50	18 x 1.0		16	187 090
	20	70	18 x 1.0		16	188 760
	25	70	25 x 1.2		16	188 761
	40	70	38 x 1.2		16	188 762
	50	70	51 x 1.2		16	188 763

Weld end acc. to BS 4825, flow direction below the seat

Control function	Orifice (mm)	Actuator size ø [mm]	Port connection tube-Ø [mm]	Minimum pilot pressure [bar]	Operating pressure up to +185°C [bar]	Item no.	
A 2/2-way valve, NC 	15	50	12.7 x 1.2	5.0	25	187 091	
	15	70	12.7 x 1.2	5.0	25	188 764	
	20	70	19.05 x 1.65	5.0	20	188 765	
	25	70	25.4 x 1.65	5.0	16	188 766	
	40	70	38.1 x 1.65	5.0	6	188 767	
	40	90	38.1 x 1.65	5.0	16	188 768	
	50	90	50.8 x 1.65	5.0	10	188 769	
		130	50.8 x 1.65	5.0	16	188 770	
	B 2/2-way valve, NO 	15	50	12.7 x 1.2	see chart on p. 2	16	187 095
		15	70	12.7 x 1.2		16	188 778
20		50	19.05 x 1.65	16		187 096	
20		70	19.05 x 1.65	16		188 779	
25		70	25.4 x 1.65	16		188 780	
40		70	38.1 x 1.65	16		188 781	
50		70	50.8 x 1.65	16		188 782	

Technical data angle seat valve Type 2100 flow direction above the seat (for gases and steam)

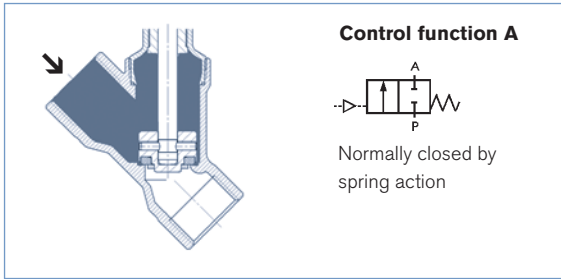

Attention!

Valves with flow above the seat are only conditionally usable for liquid medium. There is a danger of waterhammer!

Orifice [mm]	Actuator size [mm]	Kv value water (m ³ /h)	Operating pressure up to +185°C NC (A) [bar]
13	50	5.1	16
	70	5.1	16
20	50	11	16
	70	12	16
25	50	19	16
	70	19	16
32	70	28	16
40	70	38	16
	90	40	16
50	70	50	12
	90	55	16

Flow rate: Kv value water [m³/h]: Measured at +20 °C, 1 bar pressure at valve inlet and free outlet.
Pressure valves [bar]: Overpressure to the atmospheric pressure

Pressure charts with control function A and flow direction above the seat

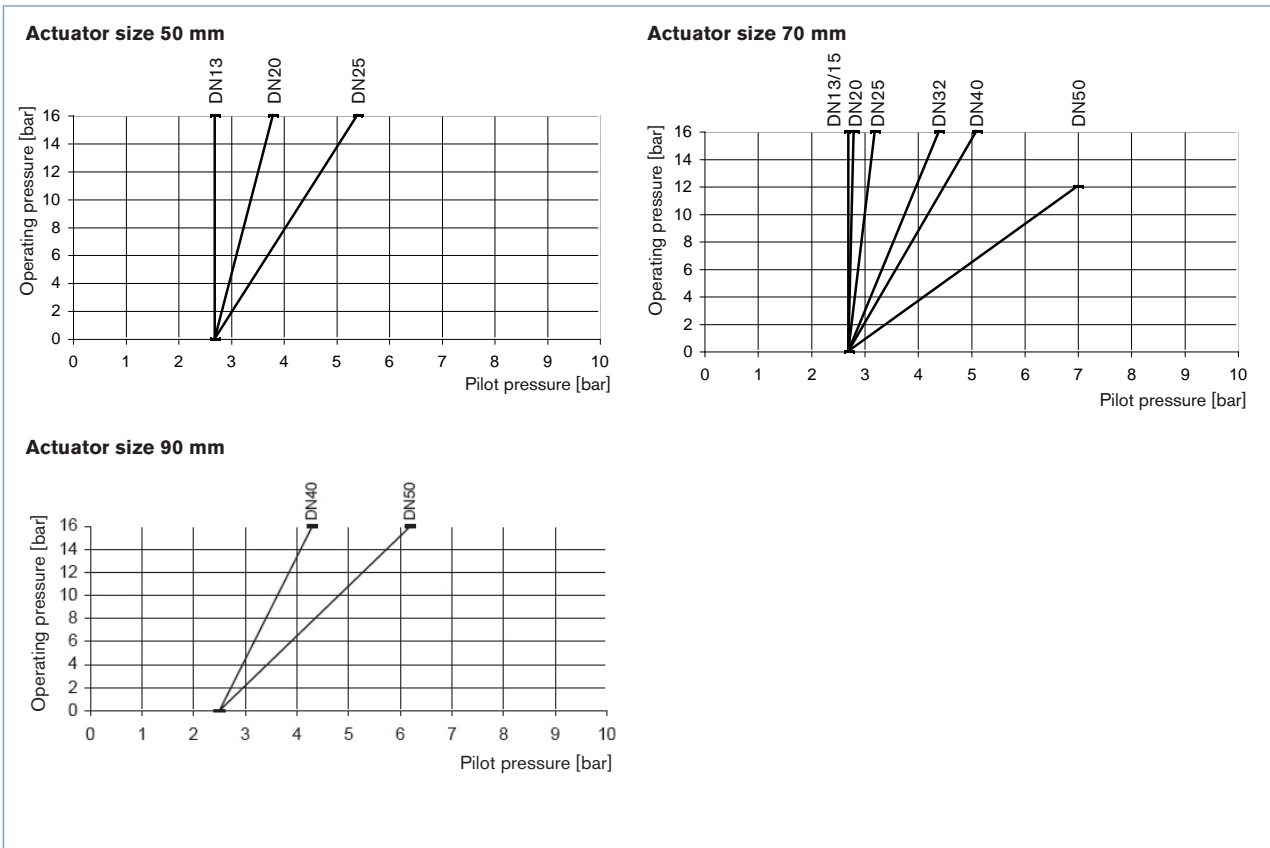

Ordering chart Type 2100 flow direction above the seat (for gases and steam), *continued*

Weld end acc. to EN ISO 1127, flow direction above the seat

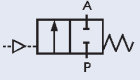
Control function	Orifice (mm)	Actuator size ø [mm]	Port connection tube-Ø [mm]	Minimum pilot pressure [bar]	Operating pressure up to +185°C [bar]	Item no.
A 2/2-way valve, NC 	15	50	21.3 x 1.6	see chart on p. 5	16	187 066
	20	50	26.9 x 1.6		16	187 067
	25	50	33.7 x 2		16	187 068
	32	70	42.4 x 2		16	188 692
	40	70	48.3 x 2		16	188 693
	50	70	60.3 x 2.6		12	188 695

Weld end acc. to DIN 11850 S2, flow direction above the seat

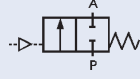
Control function	Orifice (mm)	Actuator size ø [mm]	Port connection tube-Ø [mm]	Minimum pilot pressure [bar]	Operating pressure up to +185°C [bar]	Item no.
A 2/2-way valve, NC 	15	50	19 x 1.5	see chart on p. 5	16	187 072
	20	50	23 x 1.5		16	187 073
	25	50	29 x 1.5		16	187 074
	32	70	35 x 1.5		16	188 715
	40	70	41 x 1.5		16	188 716
	50	70	53 x 1.5		12	188 718

i Further versions on request

 **Material**
Body: Stainless steel 316L

Weld end acc. to ASME BPE, flow direction above the seat

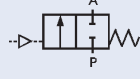
Control function	Orifice (mm)	Actuator size ø [mm]	Port connection tube-Ø [mm]	Minimum pilot pressure [bar]	Operating pressure up to +185°C [bar]	Item no.
A 2/2-way valve, NC 	15	50	12.7 x 1.65	see chart on p. 5	16	187 078
	20	50	19.05 x 1.65		16	187 079
	25	50	25.4 x 1.65		16	187 080
	40	70	38.1 x 1.65		16	188 736
	50	70	50.8 x 1.65		16	188 736
						12

Weld end acc. to SMS 3008, flow direction above the seat

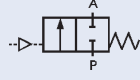
Control function	Orifice (mm)	Actuator size ø [mm]	Port connection tube-Ø [mm]	Minimum pilot pressure [bar]	Operating pressure up to +185°C [bar]	Item no.
A 2/2-way valve, NC 	15	50	12 x 1.0	see chart on p. 5	16	187 085
	20	50	18 x 1.0		16	187 086
	25	50	25 x 1.2		16	187 087
	40	70	38 x 1.2		16	188 755
	50	70	51 x 1.2		16	188 755
						12

Ordering chart Type 2100 flow direction above the seat (for gases and steam), *continued*

Weld end acc. to BS 4825, flow direction above the seat

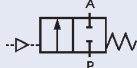
Control function	Orifice (mm)	Actuator size ø [mm]	Port connection tube-Ø [mm]	Minimum pilot pressure [bar]	Operating pressure up to +185°C [bar]	Item no.
A 2/2-way valve, NC 	15	50	12.7 x 1.2	see chart on p. 5	16	187 092
	20	50	19.05 x 1.65		16	187 093
	25	50	25.4 x 1.65		16	187 094
	40	70	38.1 x 1.65		16	188 774
	50	70	50.8 x 1.65		12	188 776

Materials angle seat valve Type 2100

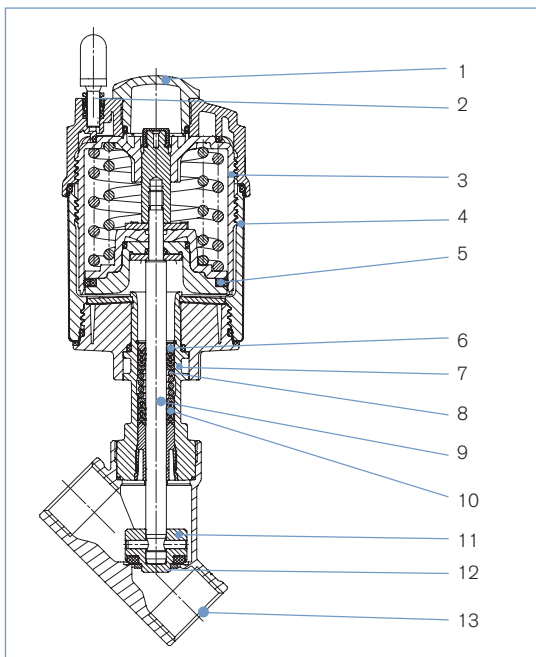

1	Optical position indicator	Transparent cap polysulfone PSU
2	Pilot air ports	Push-in connector PP (standard) <i>On request:</i> Thread G1/8" stainless steel 1.4305
3	Actuator	PPS
4	Cover	Stainless steel 1.4561 (316Ti)
5	Piston seal	FKM
6	Spring	Stainless steel 1.4310
7	Pipe	Stainless steel 1.4401 (316)/1.4404 (316L)
8	Spindle packing	PTFE
9	Spindle	Stainless steel 1.4401 (316)/1.4404 (316L)
10	Wiper	PEEK
11	Swivel plate	Stainless steel 1.4401 (316) (1.4404 (316L) on request)
12	Seals	PTFE
13	Valve body	-EN ISO 1127/ISO 4200 and DIN 11850 S 2 -ASME BPE, SMS 3008, BS 4825 Part 1 Stainless steel 1.4581 (316L on request) Stainless steel 316L

Lubricants for spindle packing and actuator are classified according NSF H1

Dimensions angle seat valve Type 2100 [mm], *continued*

Welded body

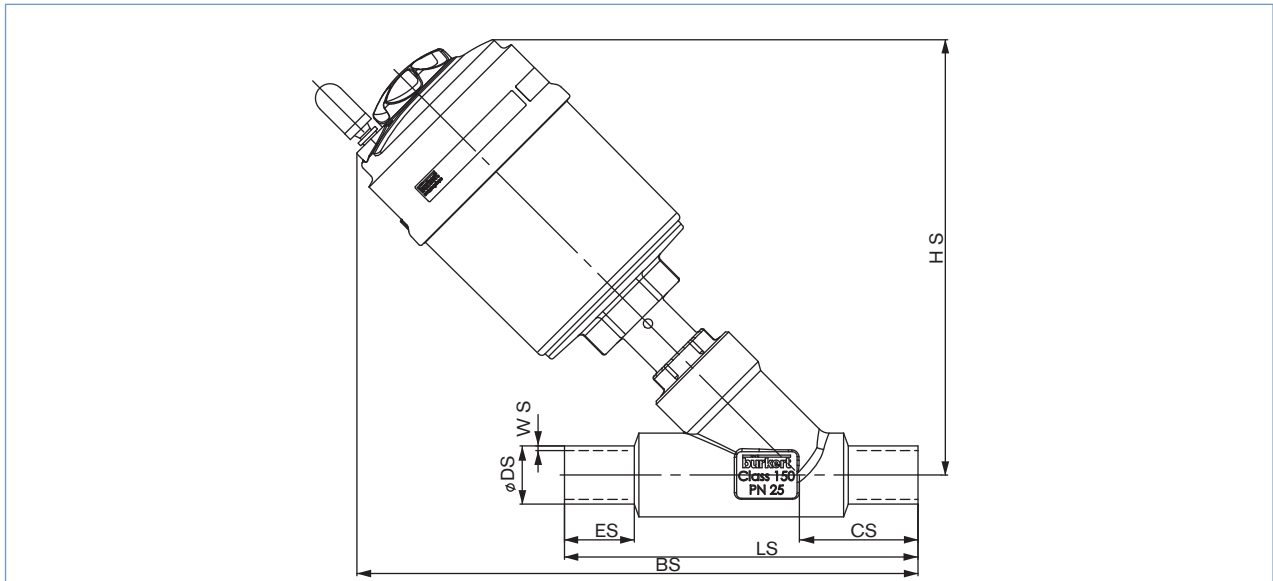

ISO 4200, SMS3008

Alle Gehäuse			ISO 4200							SMS3008						
DN [mm]	Antriebsgröße [mm]	HS	BS	CS	LS	ØDS	ES	WS	LTA	BS	CS	LS	ØDS	ES	WS	LTA
15	50	163	200	34	100	13.5	20	1.6	SA40 SA41 SA42	212	46	135	12	30	1	SA58 SA59
	70	178	216			17.2				228			18			
20	50	171	212	39	115	26.9	25	1.6	SA43	225	52	145	18	30	1	SA59 SA60
	70	186	228							241			25		1.2	
25	50	172	218	43	130	33.7	30	2	SA44	226	51	152	25	30	1.2	SA60
	70	188	234							242						
32	70	197	241	40	145	42.4	26	2	SA45	241	40	145	38	26	1.2	SA62
	90	242	283							283						
40	70	201	253	49	160	48.3	30	2	SA46	264	60	182	38	30	1.2	SA62
	90	245	296							307						
	130	296	345							356						
50	70	219	273	50	175	60.3	30	2.6	SA47	287	64	210	51	30	1.2	SA63
	90	261	312							326						
	130	312	362							376						

DIN 11850 R2. ASME BPE. BS4825

Alle Gehäuse			DIN 11850 R2							ASME BPE							BS4825						
DN [mm]	Antriebsgröße [mm]	HS	BS	CS	LS	ØDS	ES	WS	LTA	BS	CS	LS	ØDS	ES	WS	LTA	BS	CS	LS	ØDS	ES	WS	LTA
15	50	163	200	34	100	19	20	1.5	SD42	200	34	100	12.7	15	1.65	SA92	200	34	100	12.7	20	1.2	SODD
	70	178	216							216							216						
20	50	171	212	39	115	23	25	1.5	SD43	212	39	115	19.05	25	1.65	SA93	212	39	115	19.05	25	1.2	SODE
	70	186	228							228							228						
25	50	172	218	43	130	29	26	1.5	SD44	218	43	130	25.4	30	1.65	SA94	218	43	130	25.4	30	1.65	SODF
	70	188	234							234							234						
32	70	197	241	40	145	35	26	1.5	SD45	-	-	-	-	-	-	-	-	-	-	-	-	-	-
	90	242	283							283													
40	70	201	253	49	160	41	26	1.5	SD46	253	49	160	38.1	30	1.65	SA95	253	49	160	38.1	30	1.65	SODH
	90	245	296							296													
	130	296	345							345													
50	70	219	273	50	175	53	26	1.5	SD47	273	50	175	50.8	30	1.65	SA96	273	50	175	50.8	30	1.65	SODI
	90	261	312							312													
	130	312	362							362													

Ordering information for valve system On/Off ELEMENT Type 8801-YE

A valve system On/Off ELEMENT Type 8801-YE consists of an angle seat valve Type 2100 and a pneumatic control unit Type 8690, control head Type 8691 (for valve actuator sizes $\varnothing 70/\varnothing 90/\varnothing 130\text{mm}$) or control head Type 8695 (for valve actuator size $\varnothing 50\text{ mm}$) (see separate datasheets).

For the configuration of further valve systems please use the "Request for quotation" on p. 14 [go to page](#)

You order two components and receive a complete assembled and certified valve.

Ordering the valve system On/Off ELEMENT Type 8801-YE with valve actuator sizes $\varnothing 70/\varnothing 90/\varnothing 130\text{mm}$

**Angle seat valve Type 2100 with
actuator sizes $\varnothing 70/\varnothing 90/\varnothing 130\text{ mm}$**

Control units

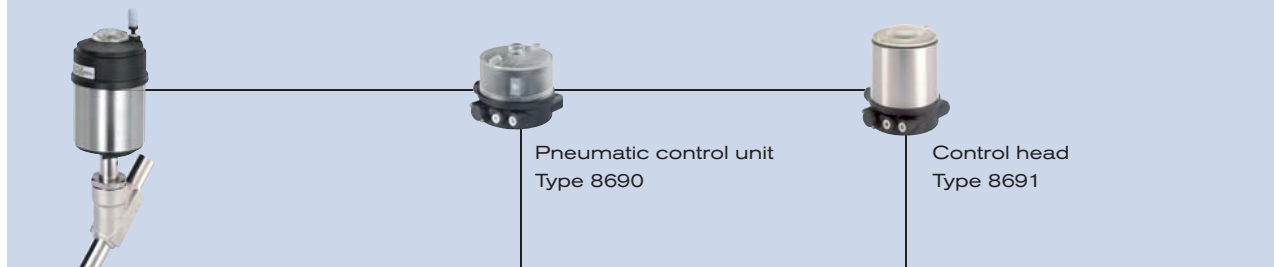

Pneumatic control unit
Type 8690

Control head
Type 8691

**Angle seat valve
with desired control unit**



**Valve system On/Off
ELEMENT Type 8801-YE-K
2100 + 8690**

**Valve system On/Off
ELEMENT Type 8801-YE-H
2100 + 8691**

Click on the orange box "More info." below... you will come to our website for the resp. product where you can download the datasheet.

Pneumatic control unit Type 8690



**More
info.**

The new generation of integrated controllers for combination with actuators from the process valve series Type 21xx is specially designed for the requirements of hygienic process environments. The pneumatic control unit Type 8690 combines electrical position feedback and pneumatic control for single or double-acting actuators, and is also optionally available as an intrinsically safe model to ATEX.

Main customer benefits:

- Compact design of the valve system with integrated controller meets the demands for plant washdown environments through the selection of materials, external seals and integrated control air supply to the actuator.
- Integrated pilot valve with manual actuation
- Air intake filter enhances the process valve system availability
- Simple and reliable actuator adaptations allowing additional actuators of the process valve series, Type 20xx or actuators from other manufacturers to be used

Control head Type 8691



**More
info.**

The new generation of integrated control heads for combination with actuators from the process valve series Type 21xx is specially designed for the requirements of hygienic process environments. The intelligent control head, Type 8691, detects the valve position by means of a contact-free analog position sensor circumventing excessive wear of mechanical parts. Single or double-acting actuators are controlled via the integral pilot valve. Communication interfaces AS-Interface and DeviceNet are available as options.

Main customer benefits:

- Compact, hygienic design of the valve system with integrated controller meets the demands of plant washdown environments through the selection of materials, external seals and integrated control air supply to the actuator.
- Automatic setting of the control head at the push of a button
- Even under dirty or dark environments, a clearly visible status display due to powerful LEDs
- Monitoring and diagnosis: Process valve systems with field bus interface used in modern plant processes
- Integrated pilot valve with manual actuation
- Air intake filter enhances the process valve system availability
- Simple and reliable actuator adaptations allowing additional actuators of the process valve series, Type 20xx or actuators from other manufacturers to be used

Ordering information for valve system On/Off ELEMENT Type 8801-YE, *continued*

A valve system On/Off ELEMENT Type 8801-YE consists of an angle seat valve Type 2100 and a pneumatic control unit Type 8690, control head Type 8691 (for valve actuator sizes $\varnothing 70/\varnothing 90/\varnothing 130$ mm) or control head Type 8695 (for valve actuator size $\varnothing 50$ mm) (see separate datasheets).

For the configuration of further valve systems please use the "Request for quotation" on p. 14 [go to page](#)

You order two components and receive a complete assembled and certified valve.

Ordering the valve system On/Off ELEMENT Type 8801-YE with valve actuator size $\varnothing 50$ mm

Angle seat valve Type 2100 with actuator size $\varnothing 50$ mm



Control unit



Control head
Type 8695

Angle seat valve with desired control unit



Valve system On/Off
ELEMENT Type 8801-YE-M
2100 + 8695

Click on the orange box "More info." below... you will come to our website for the resp. product where you can download the datasheet.

Control head Type 8695



More info.

The new generation of integrated control heads for combination with small actuators from the process valve series Type 21xx is specially designed for the requirements of hygienic process environments. The intelligent control head, Type 8695, detects the valve position by means of a contact-free analog position sensor circumventing excessive wear of mechanical parts. Single and double-acting actuators are controlled via the integral pilot valve. An AS-Interface communication interface is available as an option.

Main customer benefits:

- Compact, hygienic design of the valve system with integrated controller meets the demands of plant washdown environments through the selection of materials, external seals and integrated control air supply to the actuator
- Automatic setting of the control head at the push of a button
- Visual status display on the control head
- Monitoring and diagnosis: Process valve systems with fieldbus interface used in modern plant processes
- Integrated pilot valve
- Simple and reliable actuator adaption

Dimensions for valve system On/Off ELEMENT Type 8801-YE [mm]

Dimensions valve system On/Off ELEMENT Type 8801-YE with pneumatic control unit Type 8690 [mm]

Welded body

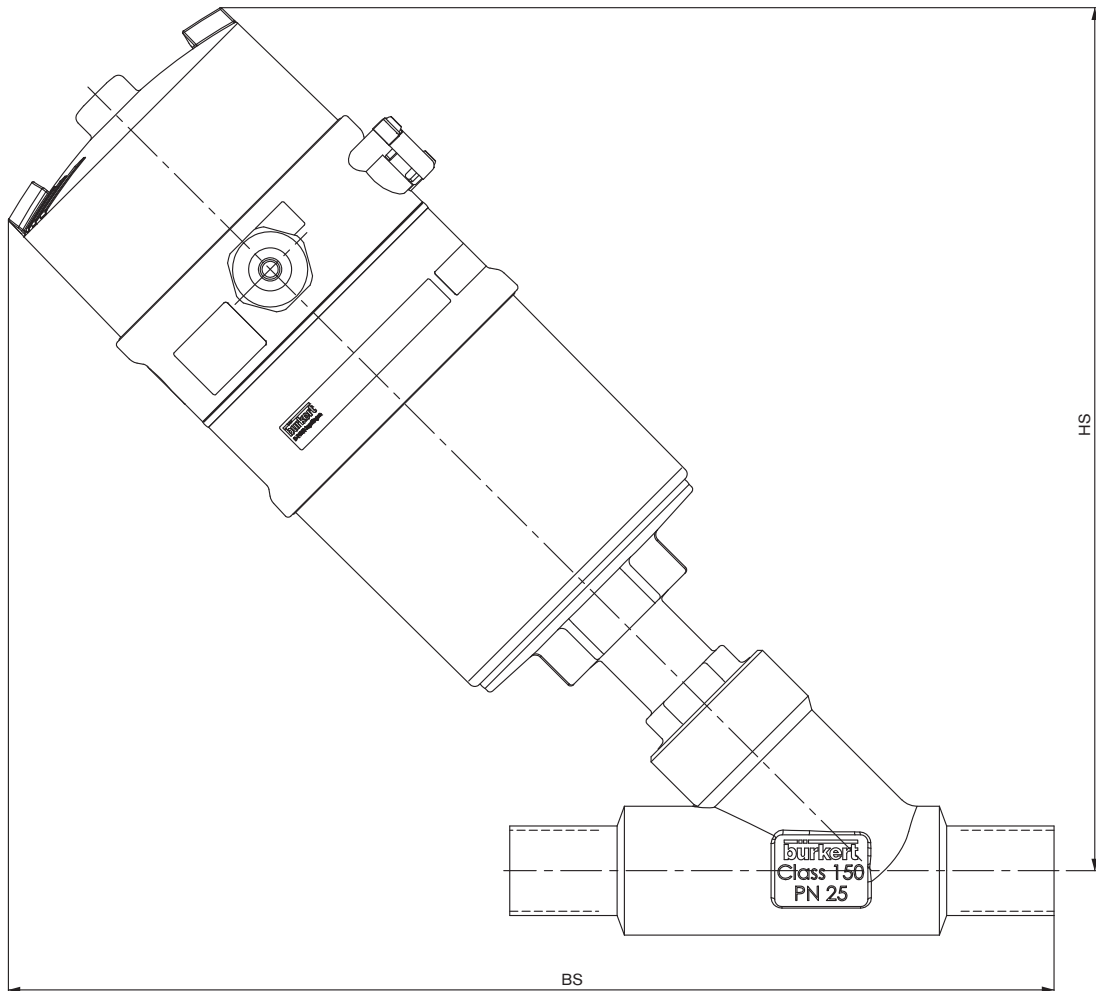

Orifice [mm]	Actuator size [mm]	acc.to ISO 4200 DIN 11850 R2 ASME BPE BS 4825			acc. to SMS 3008
		HS	BS	BS	
13	70	232	270	282	
20	70	240	282	295	
25	70	242	288	296	
32	70	251	295	295	
	90	294	335	335	
40	70	255	307	318	
	90	297	348	359	
	130	334	383	394	
50	70	273	327	341	
	90	313	364	378	
	130	350	400	414	

Dimensions for valve system On/Off ELEMENT Type 8801-YE [mm], *continued*

Dimensions valve system On/Off ELEMENT Type 8801-YE with control head Type 8691 [mm]

Welded body

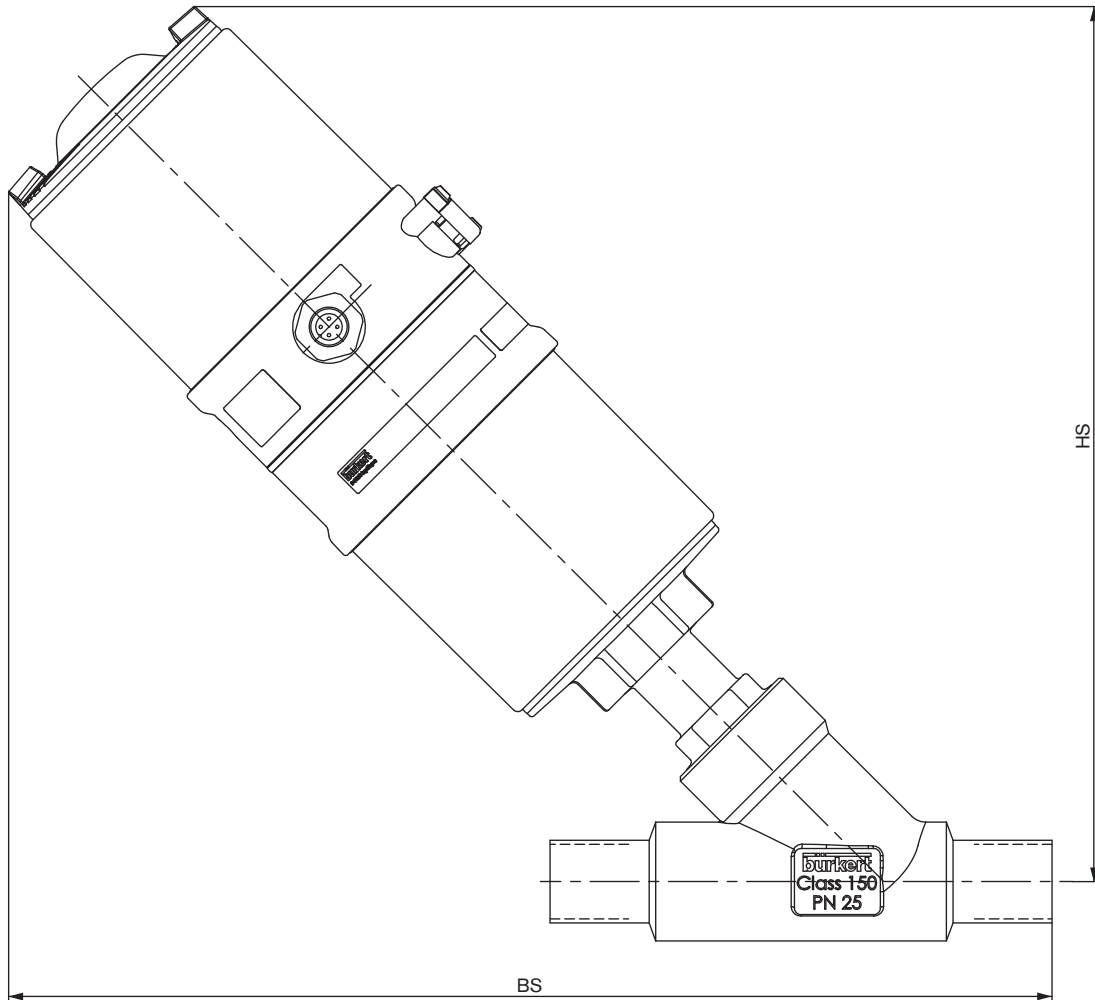

Orifice [mm]	Actuator size [mm]		acc. to ISO 4200 DIN 11850 R2 ASME BPE BS 4825	acc. to SMS 3008
		HS	BS	BS
13	70	256	294	306
20	70	264	306	319
25	70	266	312	320
32	70	275	319	319
	90	318	359	359
40	70	279	331	342
	90	321	372	383
	130	358	407	418
50	70	297	351	365
	90	337	388	402
	130	374	424	438

Dimensions for valve system On/Off ELEMENT Type 8801-YE [mm], *continued*

Dimensions valve system On/Off ELEMENT Type 8801-YE with control head Type 8695 [mm]

Welded body

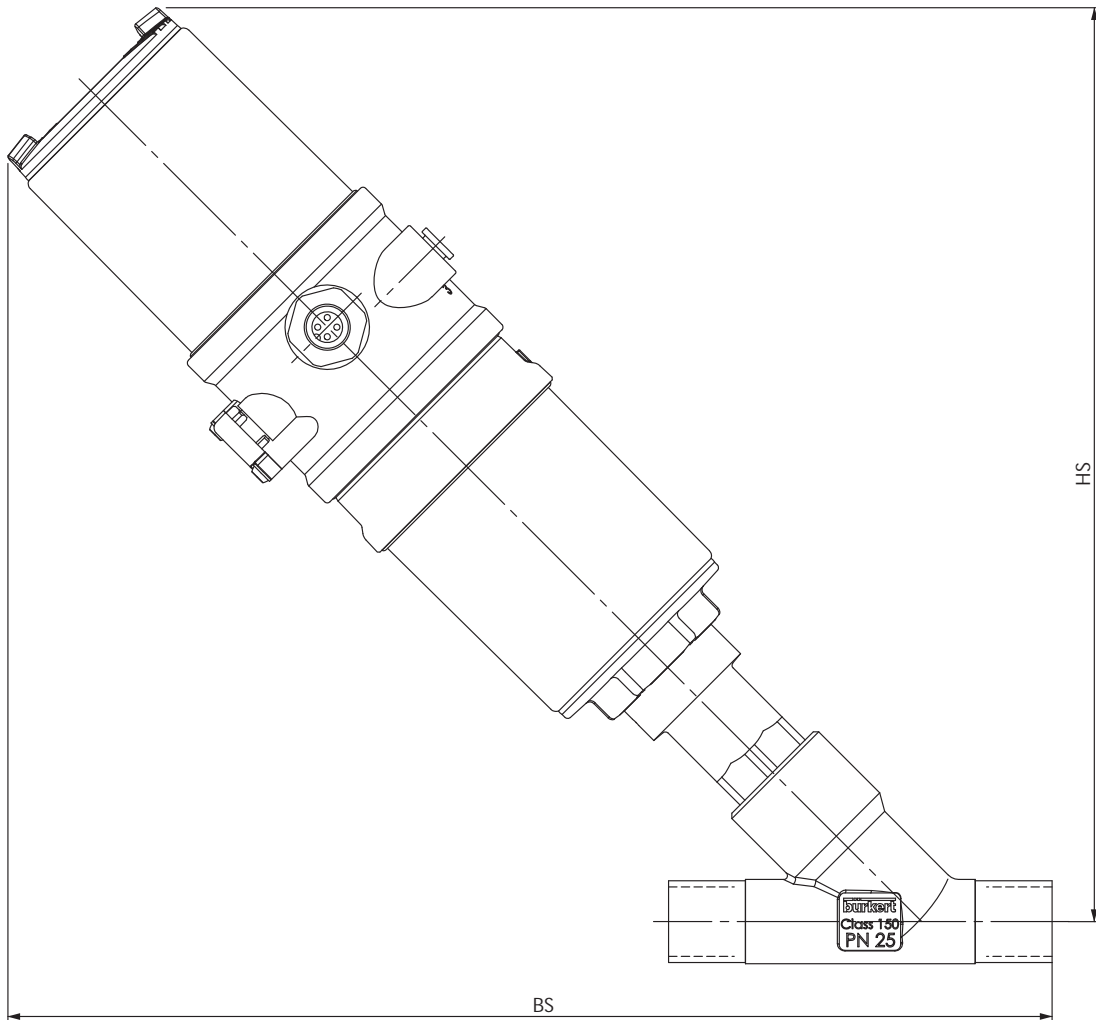

Orifice [mm]	Actuator size [mm]		acc. to ISO 4200 DIN 11850 R2 ASME BPE BS 4825	acc. to SMS 3008
		HS	BS	BS
13/15	50	239	276	288
20	50	247	288	301
25	50	248	294	302

Valve system On/Off ELEMENT Type 8801-YE - Request for quotation

Note

You can fill out the fields directly in the PDF file before printing out the form.

Please fill out and send to your nearest Bürkert facility* with your inquiry or order

Company	Contact person
Customer no.	Department
Address	Tel./Fax
Postcode/town	E-mail

= mandatory fields to fill out Quantity Required delivery date

Operating data

Pipe line DN PN

Pipe material

Process medium

Type of medium Liquid Steam Gas

Valve features

Seal material PTFE NBR Other

Nominal pressure PN

Orifice DN

Type of connection Threaded Welded Clamp

Standard connection ISO DIN Other

Body material selection with welded connection, acc. to EN ISO 1127/ISO 4200 and DIN 11850 St. st. 1.4581 St. st. 316 L



Control function NC¹⁾ NO¹⁾ Double-acting

Pilot pressure min. max.

Please specify item no. if known:

¹⁾ NC: normally closed by spring action; NO: normally open by spring action

Control unit features

For actuator sizes ø70/ø90/ø130 mm		For actuator size ø50 mm
<input type="checkbox"/> Pneumatic Control Unit Type 8690 	<input type="checkbox"/> Control Head Type 8691 	<input type="checkbox"/> Control Head Type 8695 
<p>Pneumatic function</p> <p><input type="checkbox"/> Single-acting <input type="checkbox"/> Double-acting</p> <p><input type="checkbox"/> Without pilot valve</p> <p>Position feedback</p> <p><input type="checkbox"/> 1x inductive <input type="checkbox"/> 2x inductive</p> <p><input type="checkbox"/> 1x inductive (NAMUR) <input type="checkbox"/> 2x inductive (NAMUR)</p> <p><input type="checkbox"/> 1x mechanical <input type="checkbox"/> 2x mechanical</p> <p>Supply voltage</p> <p><input type="checkbox"/> 24 V / DC (ATEX Zone 2/22)</p> <p><input type="checkbox"/> Ex ia IIC T6 (ATEX Zone 1)</p> <p>Pilot air ports</p> <p><input type="checkbox"/> Push-in connector <input type="checkbox"/> Thread G 1/8" external ø 6mm or 1/4"</p> <p>Please specify item no. if known:</p> <p><input type="text"/></p>	<p>Pneumatic function</p> <p><input type="checkbox"/> Single-acting <input type="checkbox"/> Double-acting</p> <p>Pilot air ports</p> <p><input type="checkbox"/> Push-in connector external ø 6mm or 1/4"</p> <p><input type="checkbox"/> Thread G 1/8"</p> <p>Communication</p> <p><input type="checkbox"/> ASI</p> <p><input type="checkbox"/> Multipol M12</p> <p><input type="checkbox"/> Flat cable clip, 1 m cable</p> <p><input type="checkbox"/> DeviceNet</p> <p>Please specify item no. if known:</p> <p><input type="text"/></p>	<p>Pneumatic function</p> <p><input type="checkbox"/> Single-acting <input type="checkbox"/> Double-acting</p> <p><input type="checkbox"/> Push-in connector external ø 6mm or 1/4"</p> <p><input type="checkbox"/> Thread G 1/8"</p> <p>Communication</p> <p><input type="checkbox"/> ASI</p> <p>Please specify item no. if known:</p> <p><input type="text"/></p>

Comments

* To find your nearest Bürkert facility, click on the orange box → www.burkert.com

In case of special application conditions, please consult for advice.

Subject to alteration.
© Christian Bürkert GmbH & Co. KG

1110/3_EU-en_00895156