



bürkert
FLUID CONTROL SYSTEMS

Type 8202, 8222

ELEMENT and ELEMENT neutrino

Analytical Transmitter

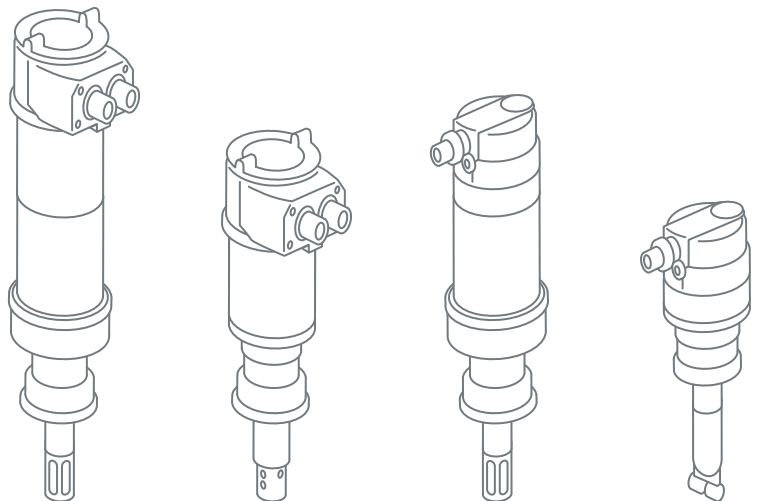



Type 8202/8222

Product Features and Resulting Advantages

Modular system

allows the selection of the device with only the required functionality, such as I/O, display and fittings as required by the given application. This allows reduced costs based on the actual features needed.

Concise and transparent software structure

Simple adjustments shorten start-up time and lower installation costs. Monitoring of sensor and transmitter status ensures high process reliability and high reproducibility of the quality of every production batch.

Standard fittings

are available for optimal selection of components at a suitable price.

Very simple exchange of sensors

minimizes workload and downtimes and saves maintenance costs.

Variable electrical connection for pH sensors (patented)

Most pH sensors on the market with 120 mm (Ø 12 mm) and S7 connections can be used; the user can select his preferred sensor, however using the same transmitter, which reduces the number of different devices in use and the effort for device management.

Robustness, premium quality, reliability, and an innovative elegant design

are combined with an appropriate purchase price and low lifetime costs.

The integrated pt1000 Sensor

allows both – built-in temperature compensation and a measurement value as a second process variable, in one device. The purchase of a separate temperature sensor is not necessary and there are no installation and lifetime costs for such a device.

The possibility of selecting 3 cell constants (0.01, 01 or 1) for conductivity measurements

provides more freedom for exchanging sensors and optimization of processes. This reduces device management costs, as a single transmitter type can be used regardless of the selected cell. Warehousing costs are saved due to reduction of spare parts diversity.

A universal process connection

offers the freedom to select the sensor which is best suited to the process.



ELEMENT neutrino Transmitter Features

The ELEMENT pH and conductivity transmitters neutrino are blind transmitters with a lower total height. They are suitable for applications which require an analogue output (4-20 mA). Significant characteristics of these transmitters are:

- Changing the measurement method pH, ORP or conductivity by pressing a key
- Operating access with keys and multi point switch
- LED as status indicator for calibration operations and device status related to alarms and warnings
- Measurement range switching with 16 point rotary switch and ranges being allocated to it
- Calibration for pH and ORP
- One-point or two-point calibration

*ELEMENT neutrino transmitter
for pH/ORP- and conductivity*



ELEMENT Transmitter Features

The pH and conductivity transmitters ELEMENT with or without graphic display are suitable for applications which require up to 2 analogue outputs (4-20 mA) and up to 2 transistor outputs. They are also suitable for the monitoring of measurements, for equipment diagnostics, convenient parameterisation and calibration.

Significant characteristics of these transmitters are:

- Illuminated removable graphic display with operation via multifunction key
 - Parameterization for optimizing device operation at the given measurement point
 - Menu guided calibration
 - Display of device diagnostics information
 - Display of measurement values
 - Limit setting for warning and error detection
 - Test functions and simulation of all outputs
 - Process value simulation
 - Selection of digital output functionality: as sink (NPN) or source (PNP)
 - Selection of unit and scale of the analogue outputs
 - Selection whether the analogue output is set to alarm current value in case of a device error
 - Adjustment of analogue output damping
- Second analogue output for temperature
- 3 LEDs for indicating device status
- 2 digital outputs for indicating limit detection or control loop function
- Verification that sensor is functioning correctly
- PC interface
- Storing of the last 10 to 20 calibration values for conductivity and pH
- Storing of min/max values

The graphic display enables comfortable reading and setting of parameters, which shortens start-up time.



The transmitter can be operated with and without this display module

*ELEMENT transmitter
for pH/ORP- and conductivity*





bürkert
FLUID CONTROL SYSTEMS

Bürkert Fluid Control Systems

Christian-Bürkert-Straße 13-17
74653 Ingelfingen
Germany

Tel. +49 (0) 7940/10-0
Fax +49 (0) 7940/10-91 204

info@burkert.com
www.burkert.com